

MOBIRO.

Pasul 5 (Montaj Coltare Plastic)

Se monteaza pe laterale (2) si (3) 2x Agatatori pt sina (Ag) folosindu-se suruburi 3.5x30 (S6) - cate 2 / coltar.

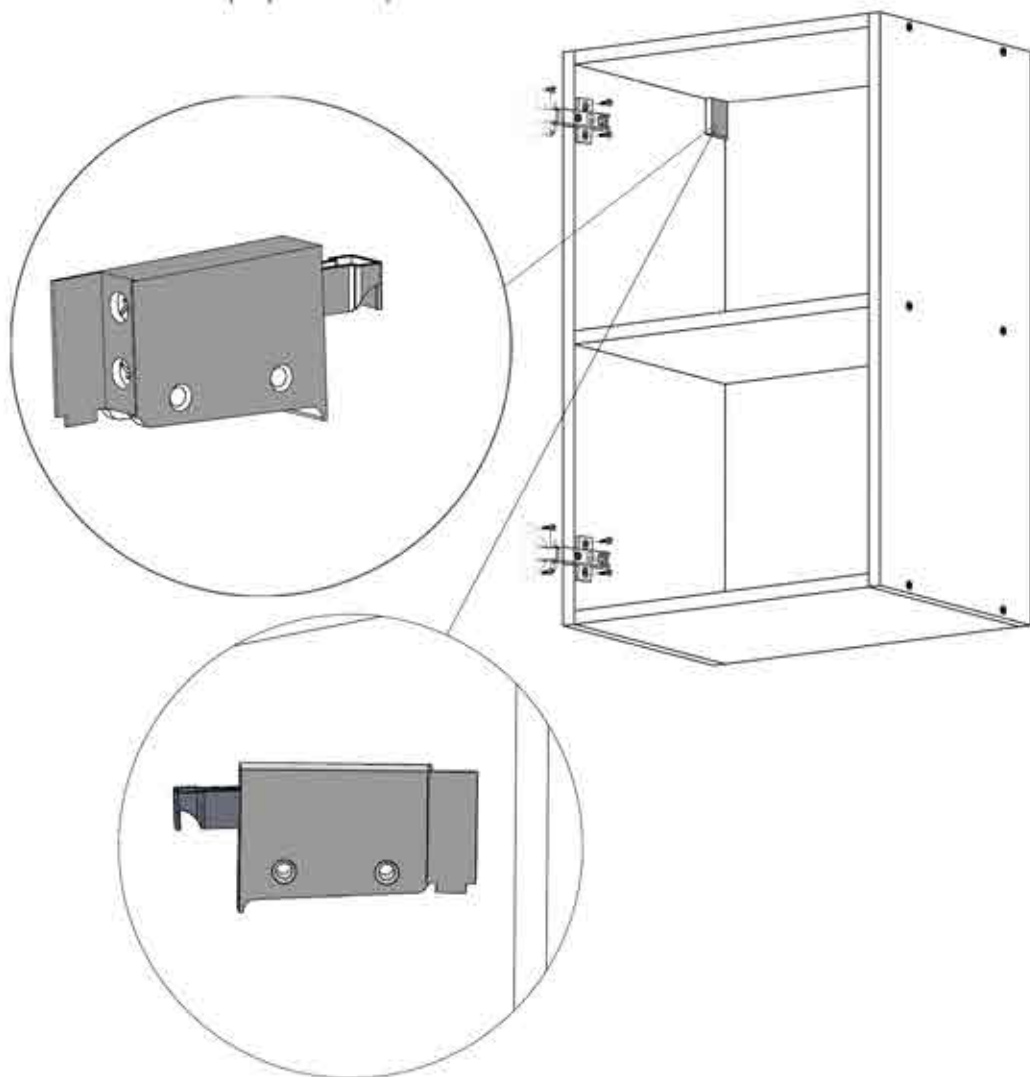

MOBIRO.

Instrucțiuni montaj: Carcasa Bucatarie - CSV 400

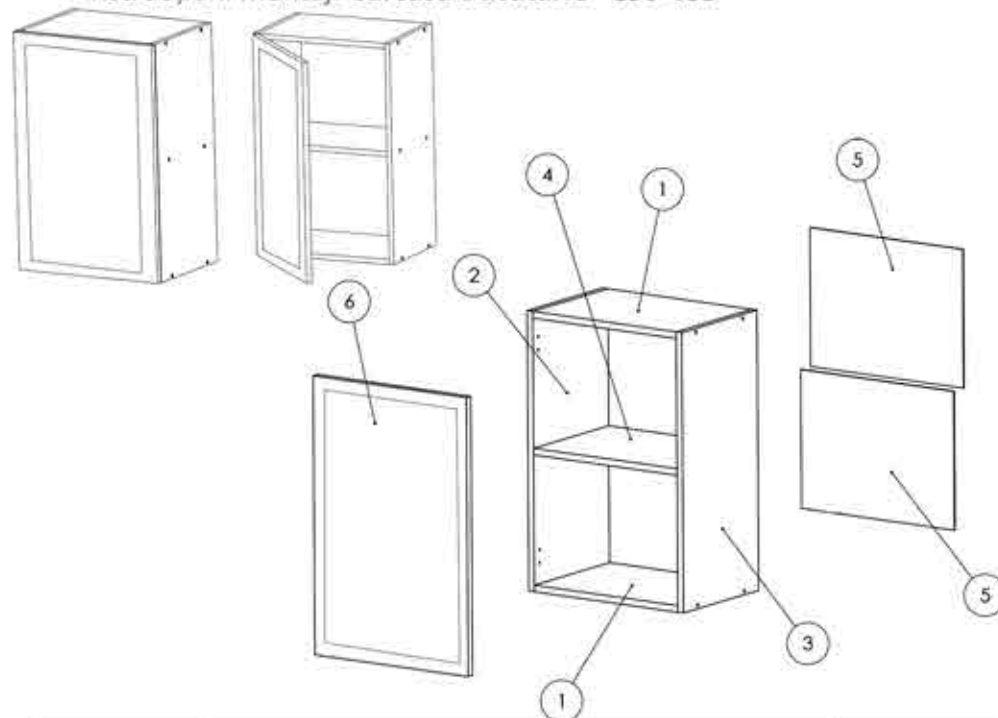

NR. REPER	DETALII	COD. REPER	CANTITATE
1	PAL368X308X16	FUND / TAVAN	2
2	PAL700X308X16	LATERALA ST.	1
3	PAL700X308X16	LATERALA DR.	1
4	368X300X6	POLITA STICLA	1
5	HDF 395X347X2.5	HDF	2
6	PAL 696X397X18	FRONT	1

ATENȚIE: MONTAJUL NECORESPUNZĂTOR ATRAGE DUPĂ SINE PIERDEREA GARANȚIEI PRODUSULUI



Șurubelniță în cruce sau autofiletantă











Este recomandat ca montajul să fie făcut de minim două persoane



Un ciocan de dimensiune medie

MOBIRO.

Elemente feronerie:

CONFIRMATOR 50mm Co  8	SURUB 4X18 S8  8	SURUB 3.5X30 S6  12	SURUB M4X22 Sm  2
SUPORT POLITA STICLA SP  4	BALAMALE APLICATE Ba  2	Agitator pt sina Ag  2	
CIUE Cu  40			

Pasul 1

Se prinde placa (2) si (3) de placile (1) cu ajutorul a 8 x Confirmatoare (Co) iar polita din sticla(4)- se fieaza pe (Sp)x4.

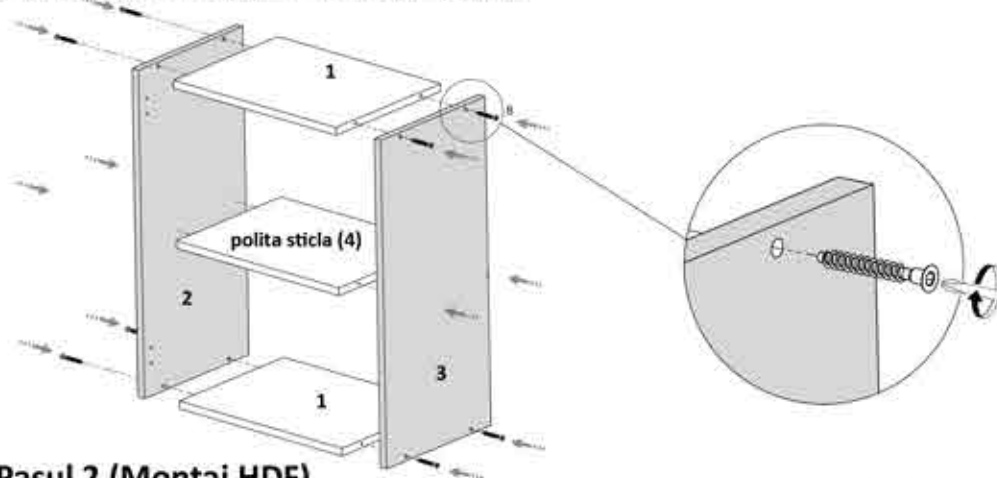

Pasul 2 (Montaj HDF)

Se masoara diagonalele sa fie in vinclu, dupa care se prinde HDF-ul (5) folosindu-se de ciocan cu ajutorul unor cuie (Cu)x 27buc, iar pe mijloc se foloseste profil pentru imbinare.

 Se masoara diagonalele sa fie in vinclu inainte de a monta HDF-ul

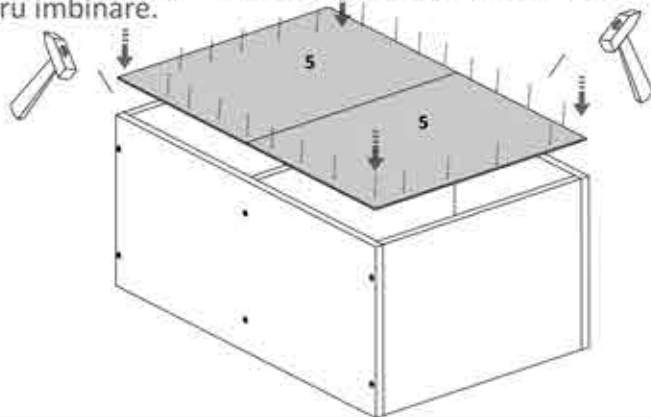

MOBIRO.

Pasul 3 (Montaj Balamale)

Se monteaza pe placa Front (6) si pe lateralele (2) si (3) balamale (Ba) folosindu-se suruburi 4x18 (S8) - cate 4 / balama

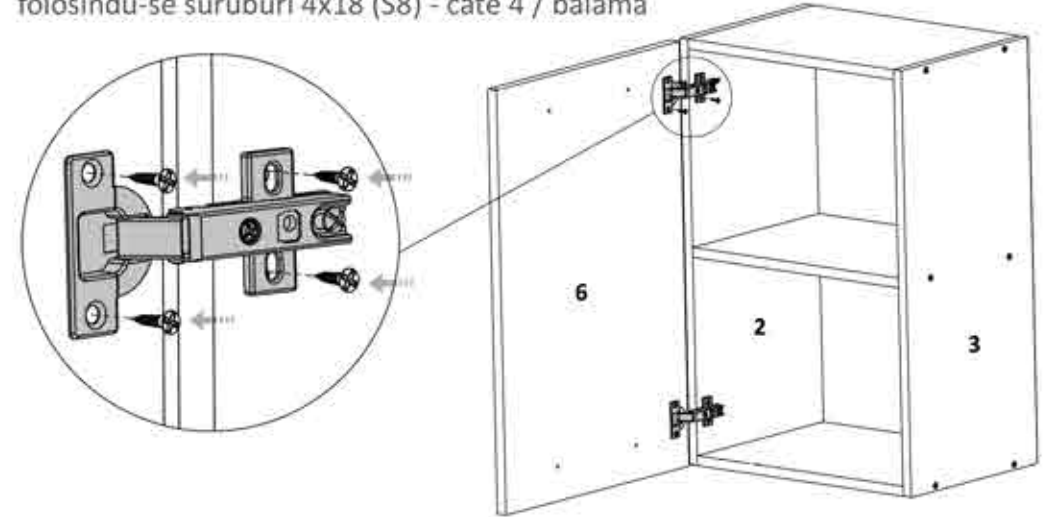

Pasul 4 (Montaj Manere pe Front)

Se monteaza pe placa Front (6) 1x maner folosindu-se suruburi M4x22 (Sm) - cate 2 / maner.

