

# MOBIRO.

## Pasul 6 (Montaj Balamale)

Se monteaza pe placa Front (6) si pe placile (4) balamale (Ba) si (Bs) folosindu-se suruburi 4x18 (S8) - cate 4 / balama.

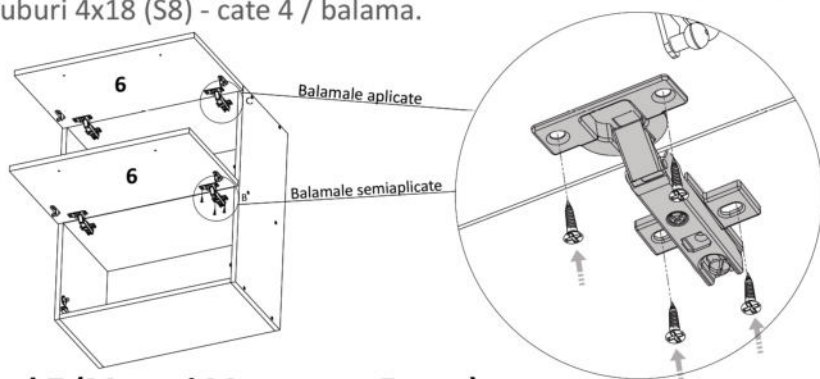

## Pasul 7 (Montaj Manere pe Front)

Se monteaza pe placile Front (6) 2x maner folosindu-se suruburi M4x22 (Sm) - cate 2 / maner .

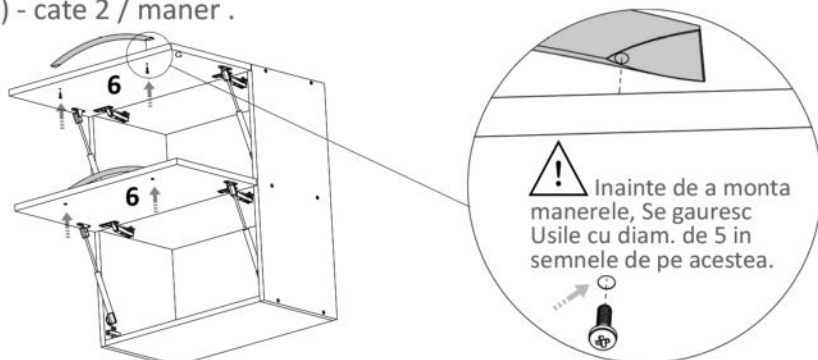

## Pasul 8 (Montaj Piston)

Se monteaza pistonul (Ps) 4x piston prin introducerea acestuia in acesoriile (TL) si (Tu) pozitionate pe usi si laterale.



# MOBIRO.

Instructiuni montaj: Corp Superior Orizontal 800 mm

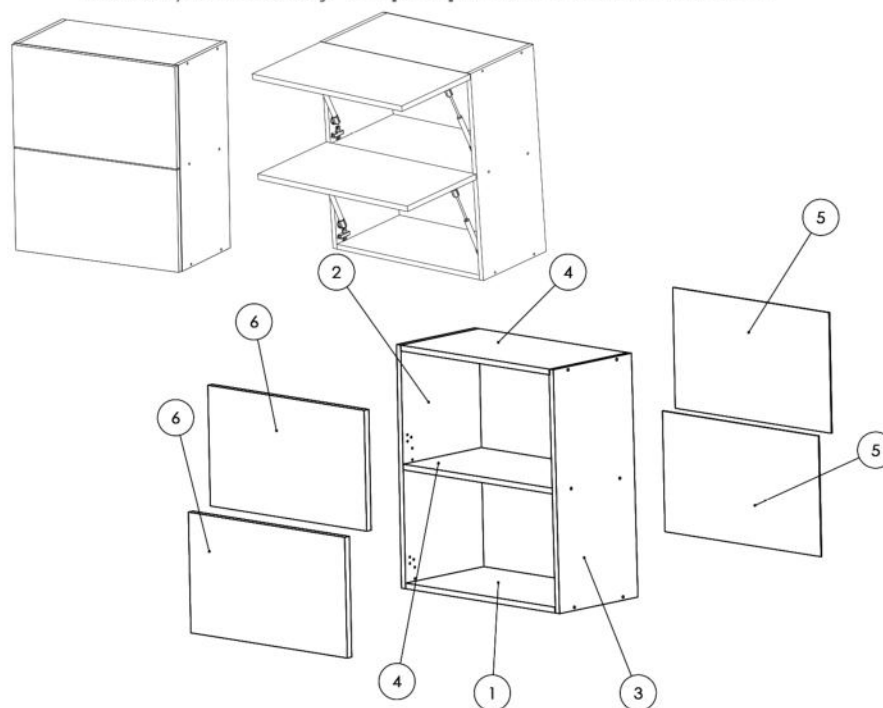

NR. REPER	DETALII	COD REPER	CANTITATE
1	PAL 768X308X16	FUND	1
2	PAL 700X308X16	LATERALA ST.	1
3	PAL 700X308X16	LATERALA DR.	1
4	PAL 768X308X16	POLITA / TAVAN	2
5	PAL 795X347X2,5	HDF	2
6	PAL 797X347X18	FRONT	2

ATENȚIE: MONTAJUL NECORESPUNZĂTOR ATRAGE DUPĂ SINE PIERDEREA GARANȚIEI PRODUSULUI



Șurubelniță în cruce sau autofiletantă













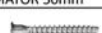



Este recomandat ca montajul să fie făcut de minim două persoane



Un ciocan de dimensiune medie

# MOBIRO.

Elemente feronerie:

CONFIRMATOR 50mm <b>Co</b>  12	SURUB 4X18 <b>S8</b>  16	SURUB 3.5X30 <b>S6</b>  12	SURUB M4X22 <b>Sm</b>  4
SAIBE TIP CUPA <b>Sc</b>  10	BALAMALE APLICATE <b>Ba</b>  2	SURUB 3.5X16 <b>S3</b>  24	Agatator pt. sina <b>Cp</b>  2
CUIE <b>Cu</b>  40	BALAMALE SEMIAPPLICATE <b>Bs</b>  2	AMORTIZOR USA <b>Am</b>  2	PISTON <b>Ps</b>  4
	TALPA LATERALA PISTON <b>TL</b>  4		TALPA USA PISTON <b>TU</b>  4

## Pasul 1 (Montaj Accesoriilor Laterale)

Se prinde pe placa (2) - 2buc x (Am) + 2buc x (TL) iar pe placa (3) - 2buc x (TL) cu ajutorul suruburilor (S3) 3.5x16 ca si in imagine.

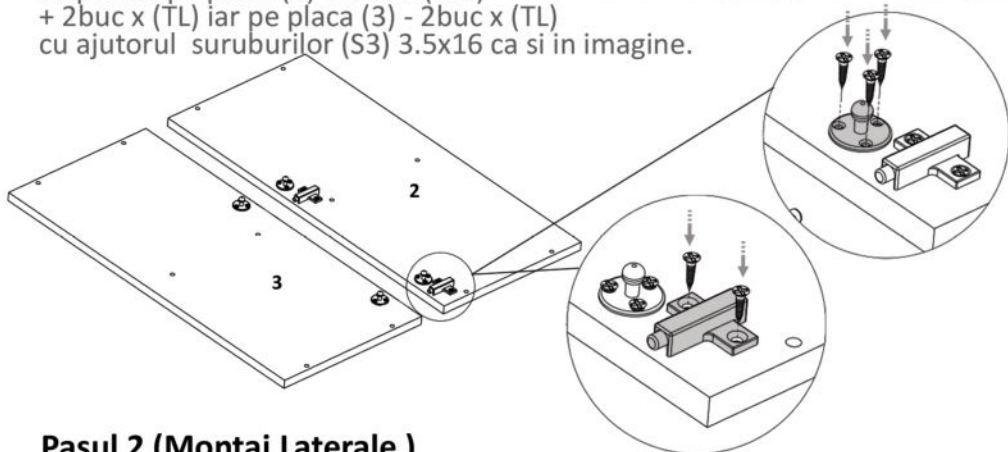

## Pasul 2 (Montaj Laterale)

Se prinde placa (2) si (3) de placile (4) cu ajutorul celor 12 x Confirmatoare (Co)

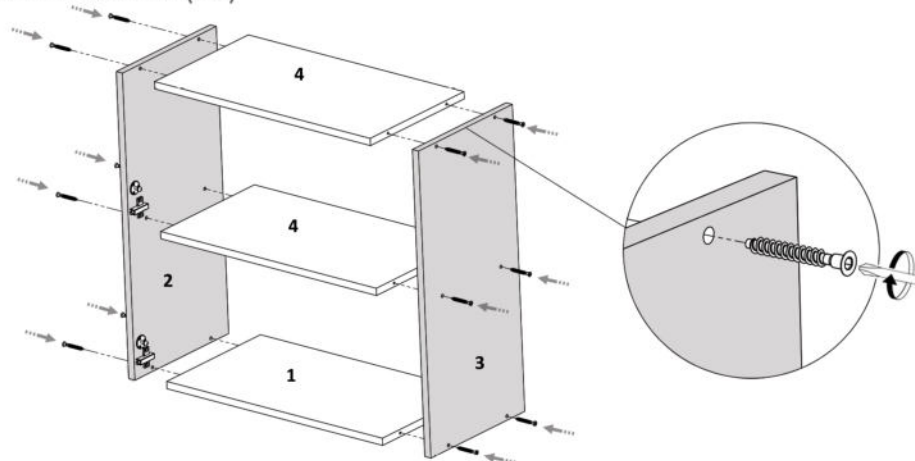

# MOBIRO.

## Pasul 3 (Montaj HDF)

Se masoara diagonalele sa fie in vinclu, dupa care se prinde HDF-ul (5) folosindu-se de ciocan cu ajutorul unor cuie (Cu)x 30 buc, iar pe mijloc se folosesc saibe tip cupa (Sc) x7buc.

 Se masoara diagonalele sa fie in vinclu inainte de a monta HDF-ul!

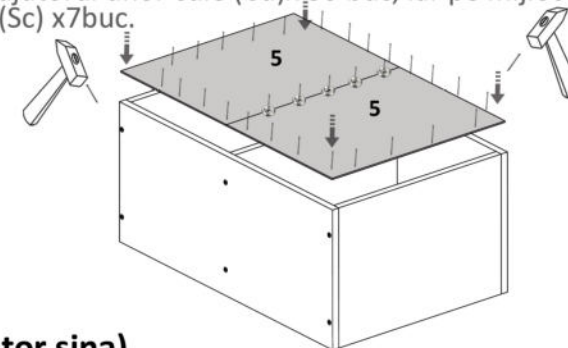

## Pasul 4 (Montaj Agatator sina)

Se monteaza pe laterale (2) si (3) 2x Agatator sina (Ag) folosindu-se suruburi 3.5x30 (S6) - cate 2 / agatator.

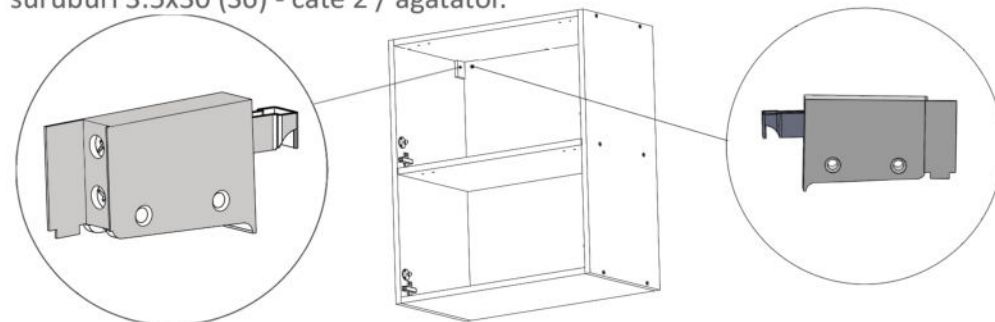

## Pasul 5 (Montaj Accesoriilor pe Usi)

Se monteaza pe fronturile (6) cate 2x (Tu) pe fiecare usa pozitionate ca si in imagine si montate in gaurile prevazute pt. acestea, urmand a se monta pistonul pe acestea.

