

# MOBIRO.

## Pasul 6 (Montaj Agatator Pt. sina )

Se monteaza pe laterale (2) si (3)  
2x Agatatori pentru sina (Ag) folosindu-se  
suruburi 3.5x30 (S6) - cate 2 / agatator

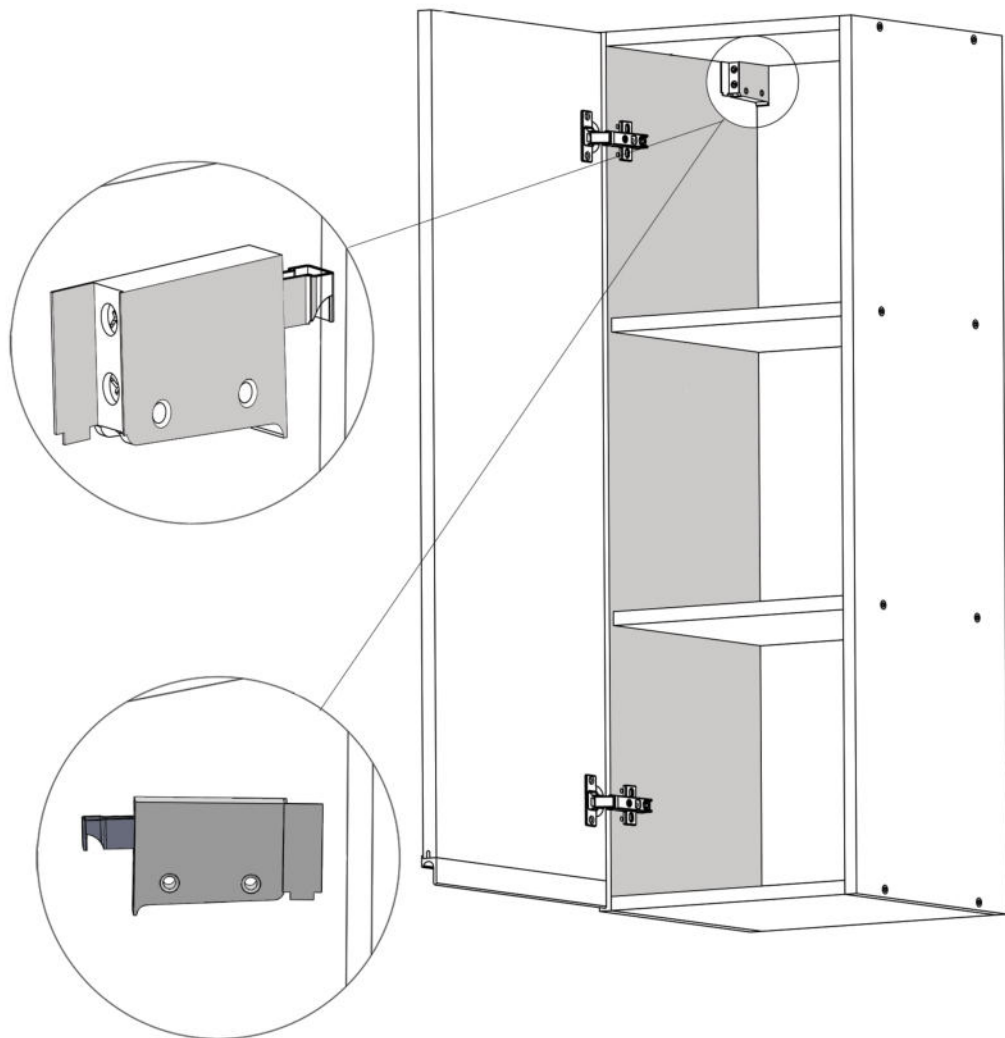

# MOBIRO.

## Instrucțiuni montaj: Corp Superior (1000)- 400 mm

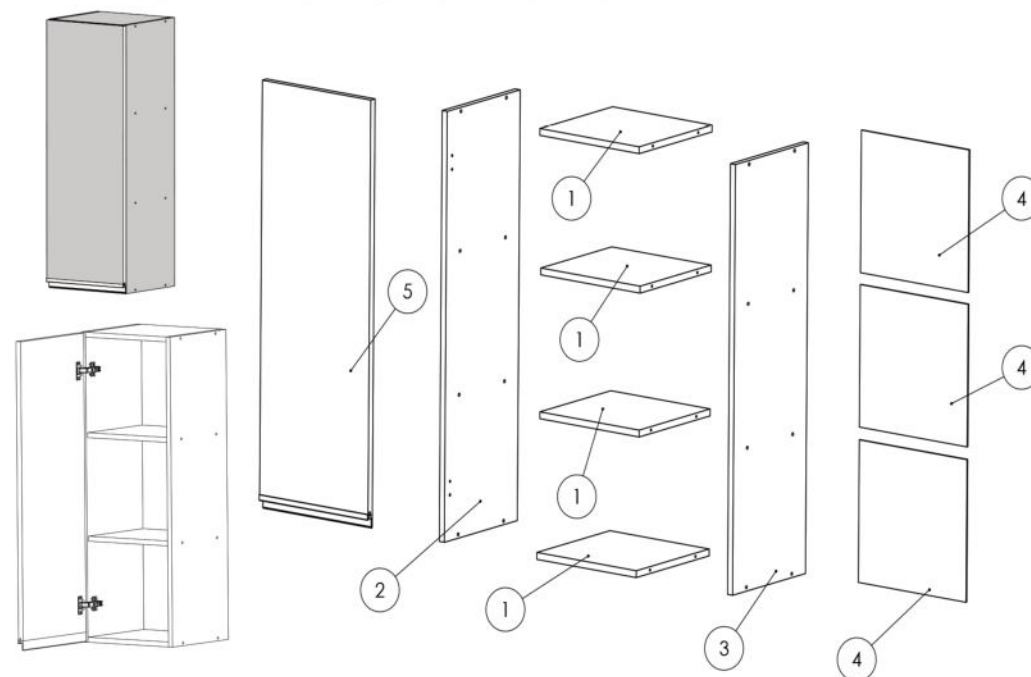

NR REPER	DETALII	COD REPER	CANTITATE
1	368X308X16	FUND/TAVAN/POLITA	4
2	1000X308X16	LATERALA STANGA	1
3	1000X308X16	LATERALA DREAPTA	1
4	331X395X2.5	HDF ALB	3
5	996X397X18	FRONT ST/DR	1

ATENȚIE: MONTAJUL NECORESPUNZĂTOR ATRAGE DUPĂ SINE PIERDEREA GARANȚIEI PRODUSULUI



Șurubelniță în cruce  
sau autofiletantă



Este **recomandat** ca  
montajul să fie făcut de  
minim două persoane



Un **ciocan** de dimensiune  
medie

# MOBIRO.

CONFIRMATOR 50mm <b>Co</b>  16	SURUB 4X18 <b>S8</b>  8	SURUB 3.5X30 <b>S6</b>  16	SURUB M4X22 <b>Sm</b>  2
CIUIE <b>Cu</b>  50	BALAMALE APLICATE <b>Ba</b>  2	SAIBE TIP CUPA <b>Sc</b>  10	COLTAR PLASTIC PVC ALB <b>Ag</b>  2

## Pasul 1

Se prinde placa (2) si (3) de placile (1) cu ajutorul a celor 16 x Confirmatoare (Co)

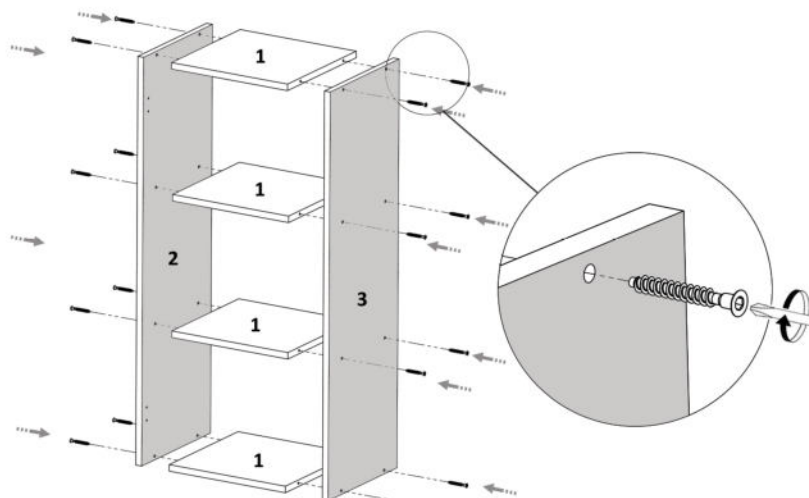

Se masoara diagonalele sa fie in vinclu, dupa care se prinde HDF-ul (4) folosindu-se de ciocan cu ajutorul unor cuie (Cu)x 50 buc.

 Se masoara diagonalele sa fie in vinclu inainte de a monta HDF-ul!

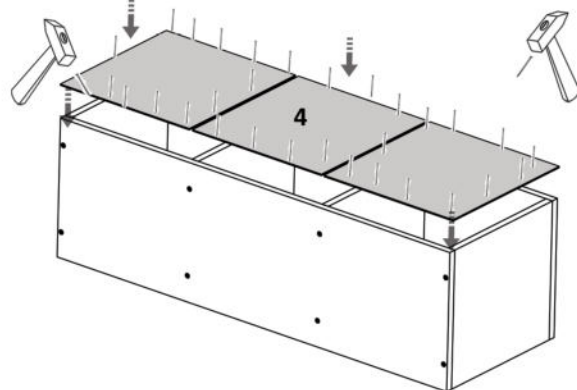

# MOBIRO.

## Pasul 4 (Montaj Balamale)

Se monteaza pe placa Front (5) si pe laterala (2) balamale (Ba) 2x balamale folosindu-se suruburi 4x18 (S8) - cate 4 / balama

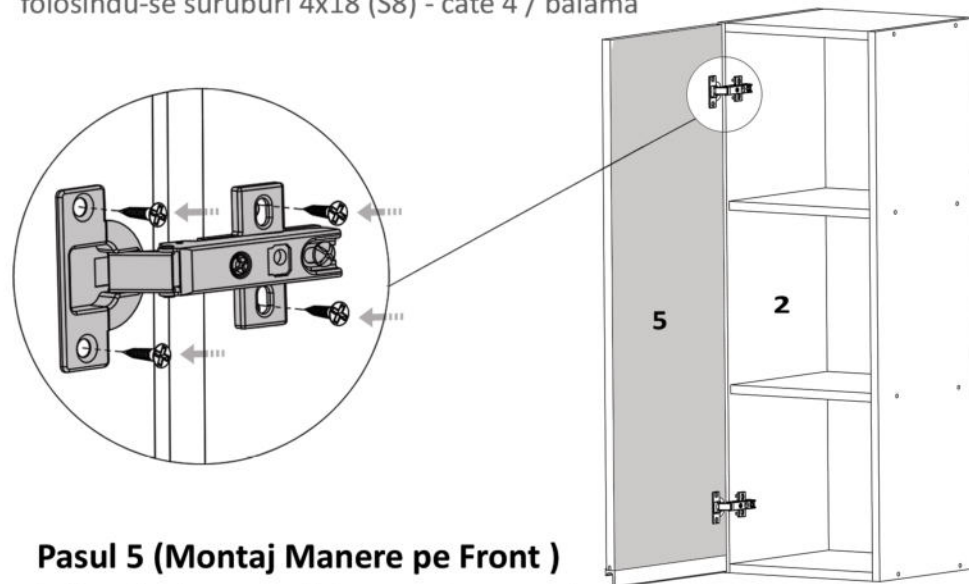

## Pasul 5 (Montaj Manere pe Front )

In functie de manerul ales, acesta se monteaza pe placa Front (5) 1x maner folosindu-se suruburi M4x22 (Sm) - cate 2 / maner.

 Inainte de a monta manerele, Se gauresc Usile cu diam. de 5 in semnele de pe acestea.

