

Tipuri de Montaj:

Corp Pozitionat Orizontal Superior (Suspendat pe perete la inaltime)

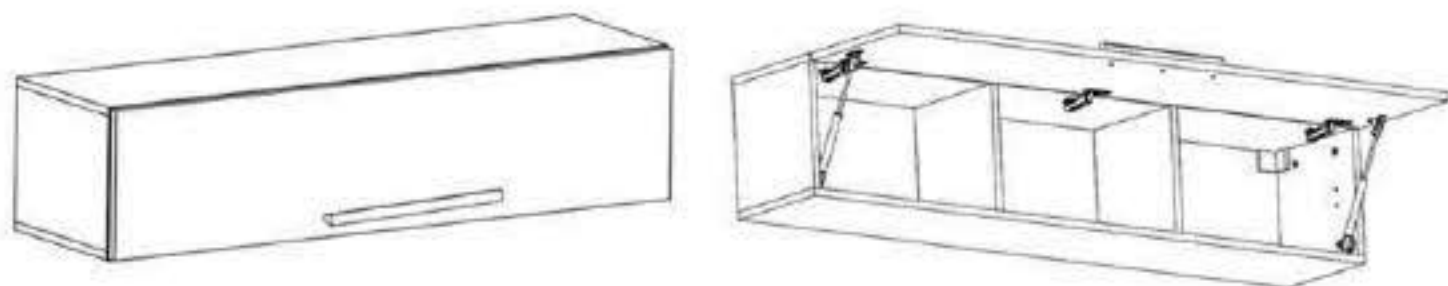

Corp Pozitionat Orizontal Inferior (Suspendat pe perete sau pe podea)

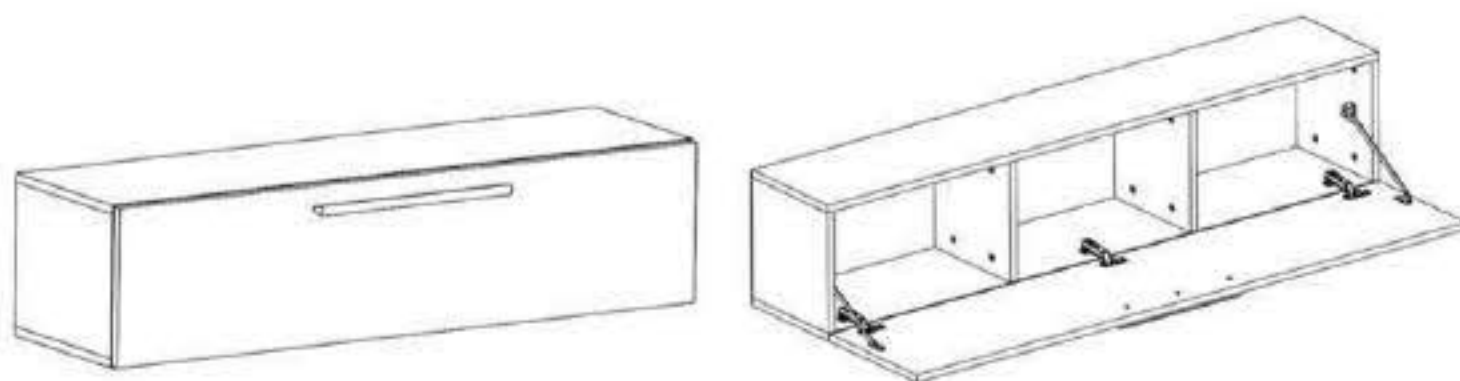

Corp Pozitionat Vertical (Suspendat pe perete sau pe podea)

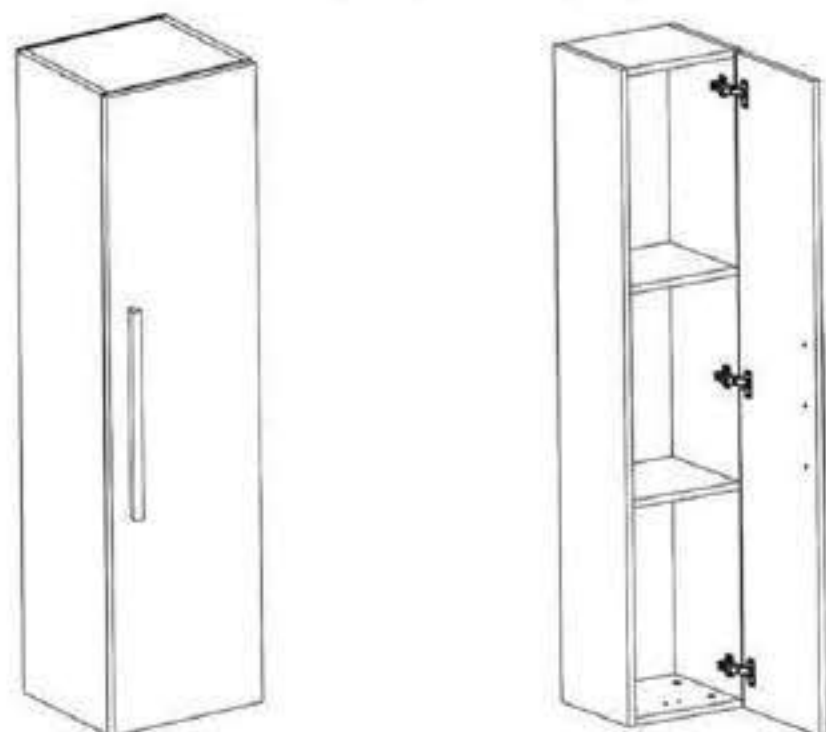

Instructiuni montaj: Corp Living Remy 1380 - Pozitie Orizontala Inferioara

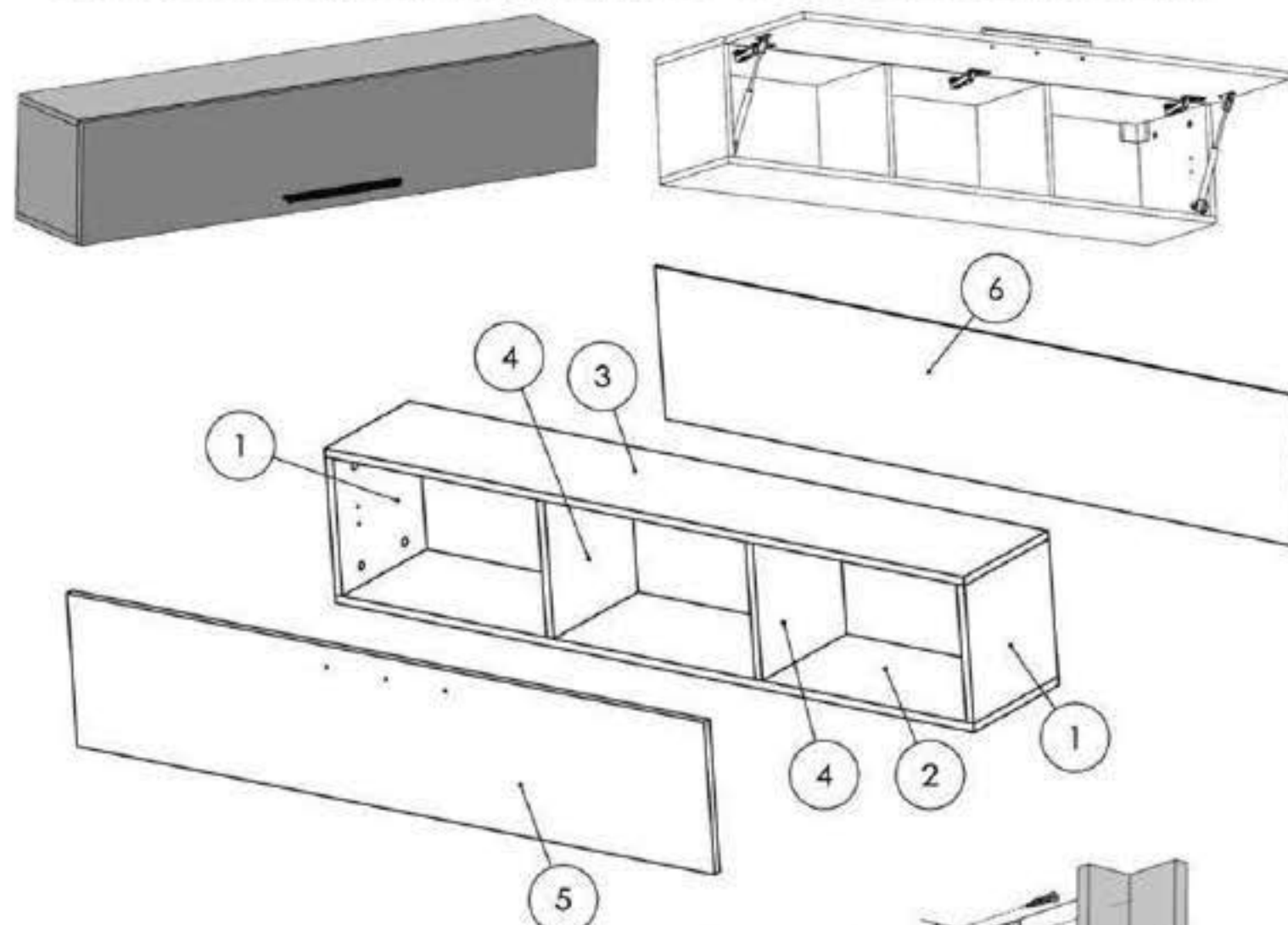

ATENȚIE: Prinderea corpurilor superioare de perete se face cu ajutorul colțarelor care trebuie montate pe corp cu (S3).

NR. REPER	DETALII	COD REPER	CANTITATE
1	PAL 258X250X16	FUND / TAVAN	2
2	PAL 1380X250X16	LATERALA DREAPTA	1
3	PAL 1380X250X16	LATERALA STANGA	1
4	PAL 258X250X16	INTERMEDIARA	2
5	PAL 1376X286X16	USA	1
6	HDF 1376X286X4	HDF	1

ATENȚIE: MONTAJUL NECORESPUNZĂTOR ATRAGE DUPĂ SINE PIERDEREA GARANȚIEI PRODUSULUI



Șurubelniță în cruce
sau autofiletantă



Este recomandat ca
montajul să fie făcut de
minim două persoane



Un ciocan de dimensiune
medie

Elemente feronerie pt. corp positionat orizontal superior:

DEMONTABIL CU EXCENTRIC De  16	Coltar Plastic Alb Cp  2	SURUB TIP CONFIRMATOR 4x27 S4  3	CAMA Ca  16
CIJIE Cu  30	TALPA LATERALA PISTON TL  2	BALAMALE APLICATE Ba  3	SURUB 3.5X16 S3  26
PISTON Ps  2	TALPA USA PISTON TU  2	MANER FIJUYA 300 Mr  1	

Pasul 1 (Montaj Demontabili)

Se prinde cu infiletanta sau surubelnita 16 x (De) pe placile laterale (2) si (3).

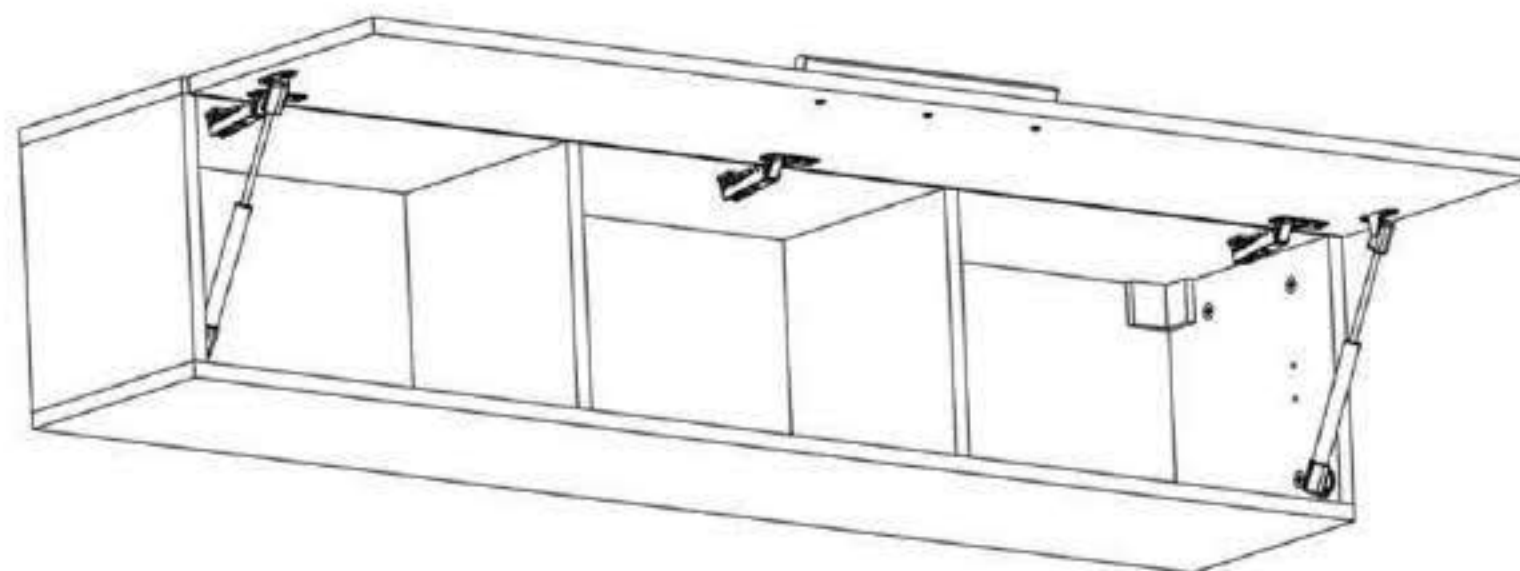
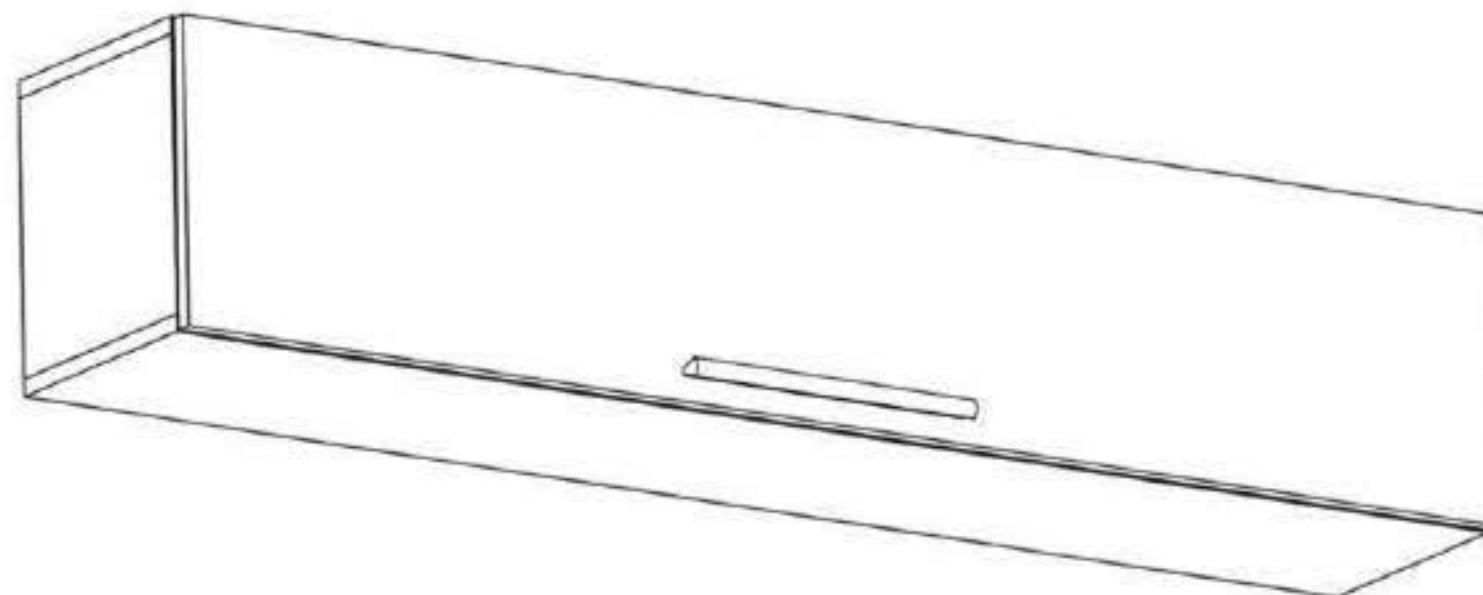
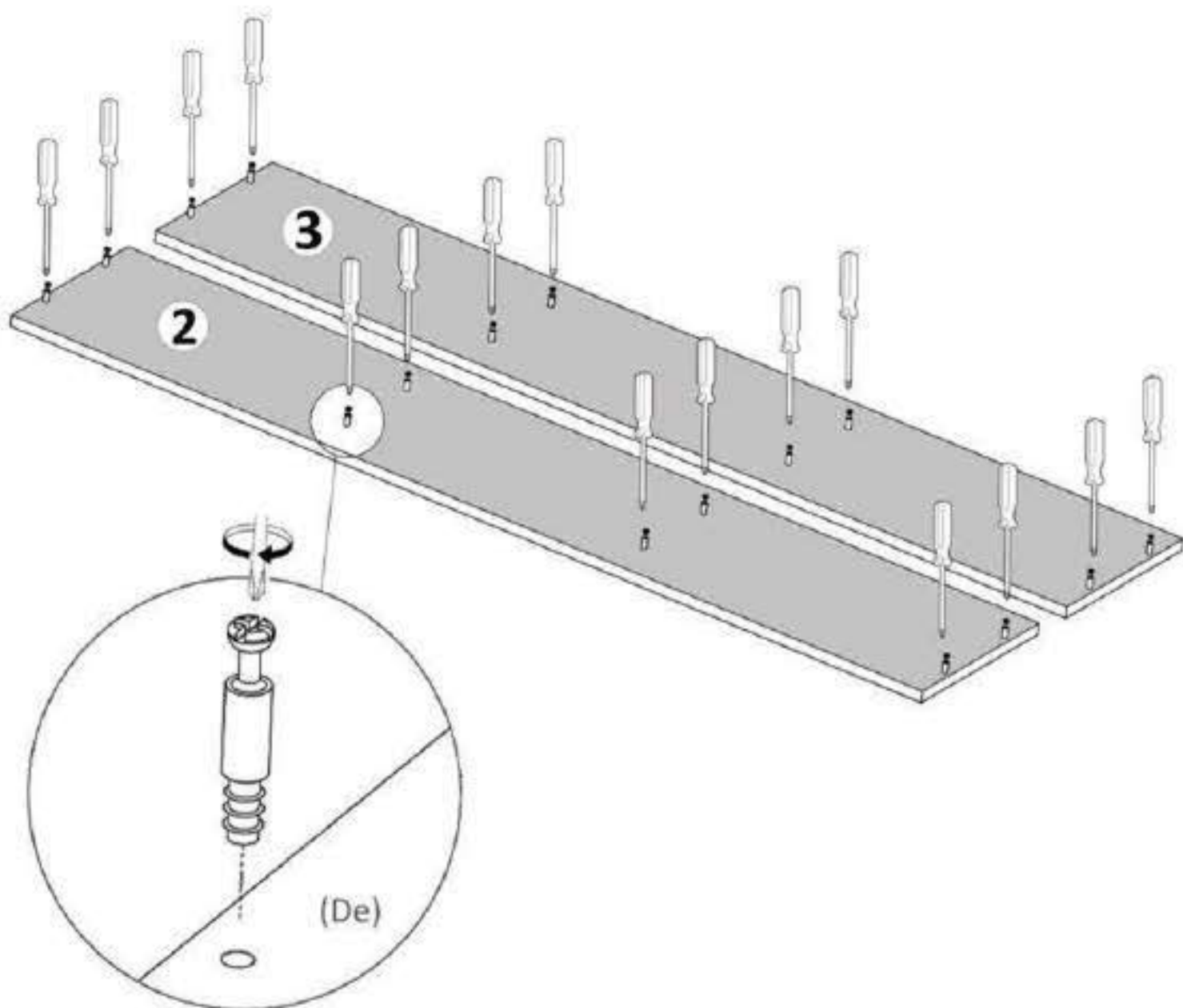

Pasul 13 (Montaj Maner)

Se monteaza pe placa (5) maner (Mn) x 1 buc cu suruburi (S4) M4x27 - 3 buc in gaurile existente pe placa.

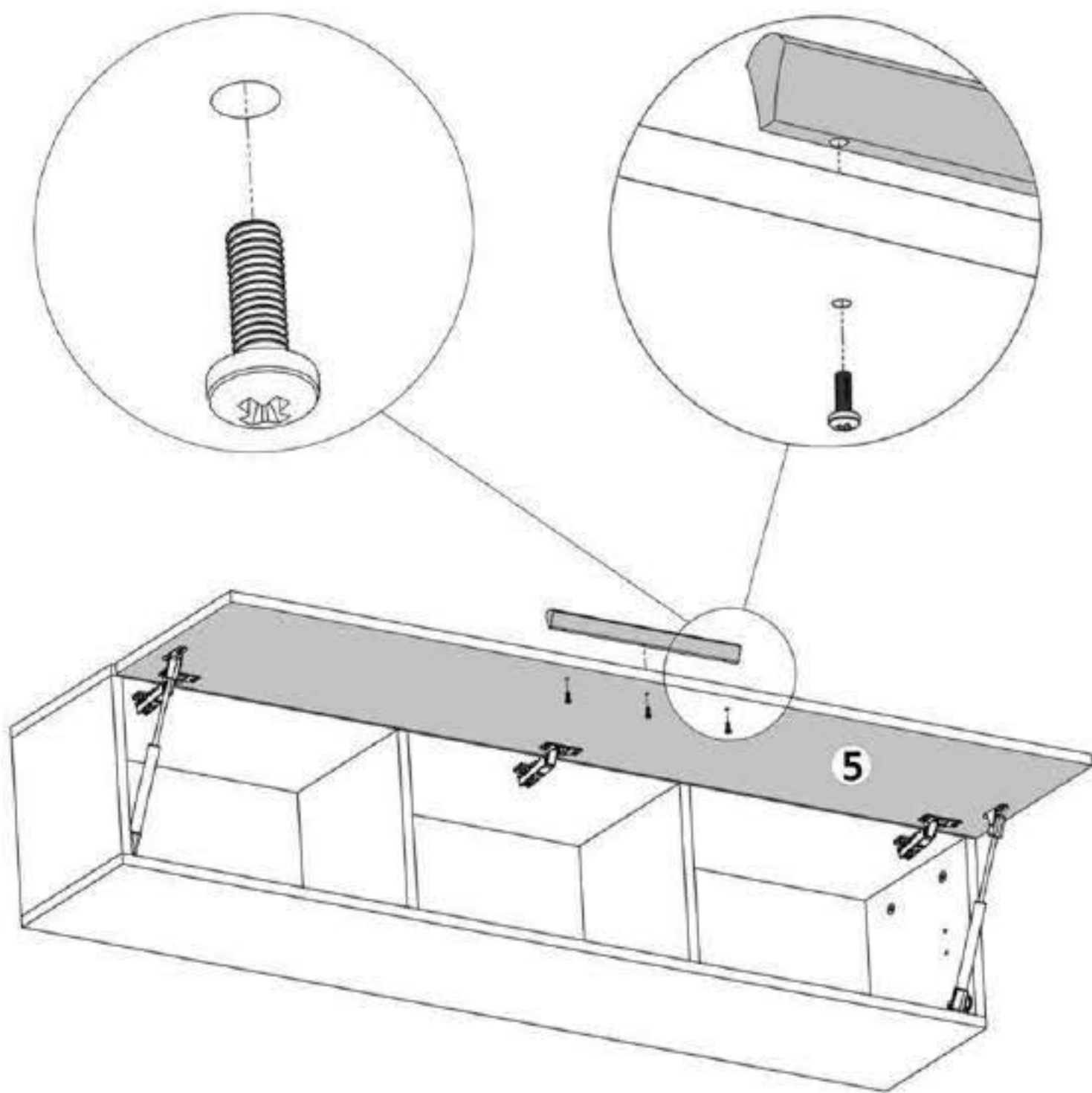

Pasul 2 (Semne pt. talpa laterala piston)

Se pozitioneaza sablonul de hartie cu inscriptia (**Sablon Aplicare Piston Gaz Usa - Se Foloseste la Aplicarea pe Lateral Stanga**) pe una din placile (1) si se perforeaza cele trei gauri cu un creion ca si in imaginea de mai jos rezultand astfel semnele necesare pentru montajul piesei (TL). (**detaliu 2**)

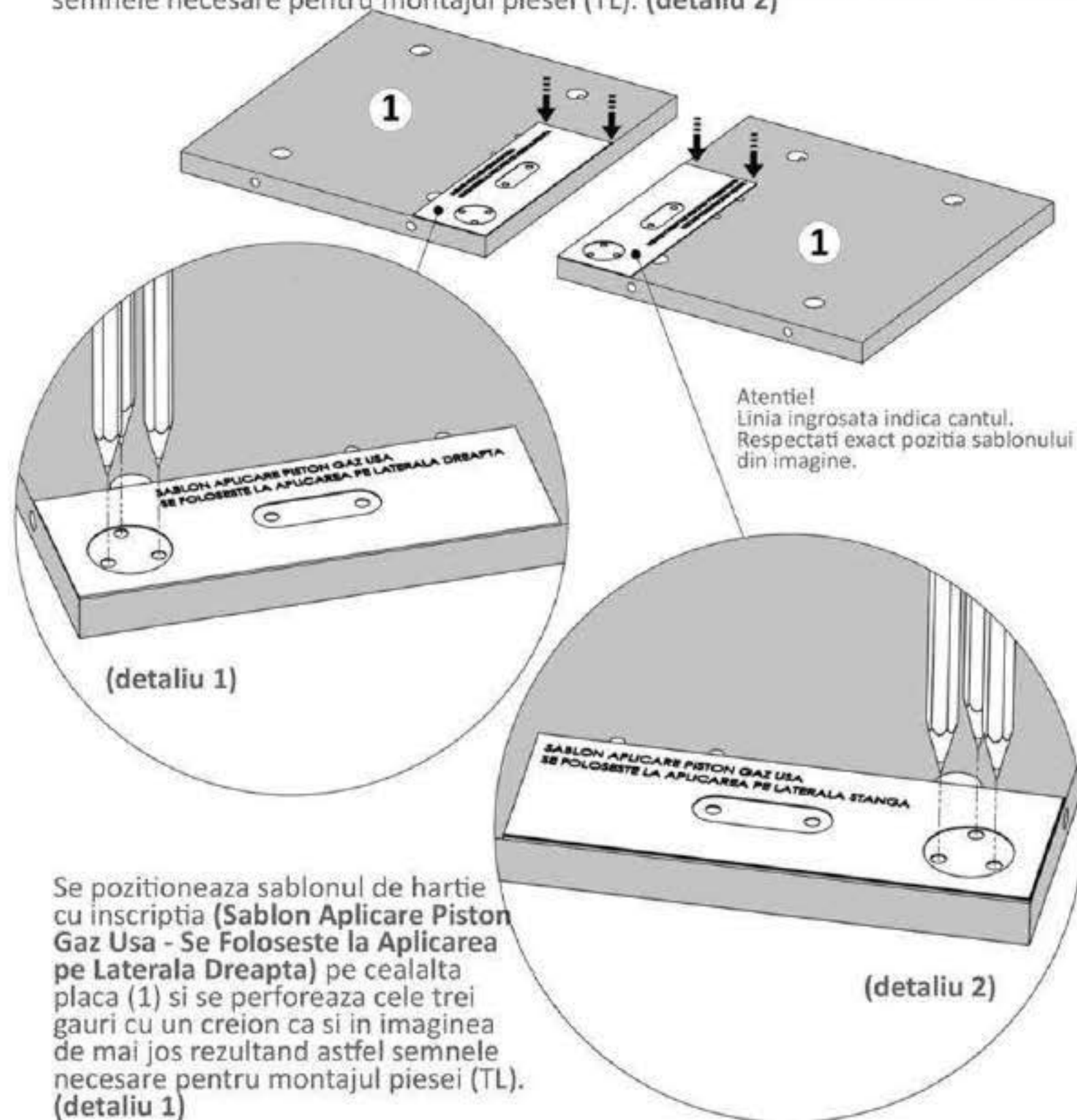

Se pozitioneaza sablonul de hartie cu inscriptia (**Sablon Aplicare Piston Gaz Usa - Se Foloseste la Aplicarea pe Lateral Dreapta**) pe cealalta placa (1) si se perforeaza cele trei gauri cu un creion ca si in imaginea de mai jos rezultand astfel semnele necesare pentru montajul piesei (TL). (**detaliu 1**)

Pasul 3 (Montaj talpa laterala piston)

Se pozitioneaza (TL) x 2 buc pe placile (1) in locurile pe care le-ati insemnat inainte cu creionul si se prind cu suruburi (S3) 3.5x16 -3buc.

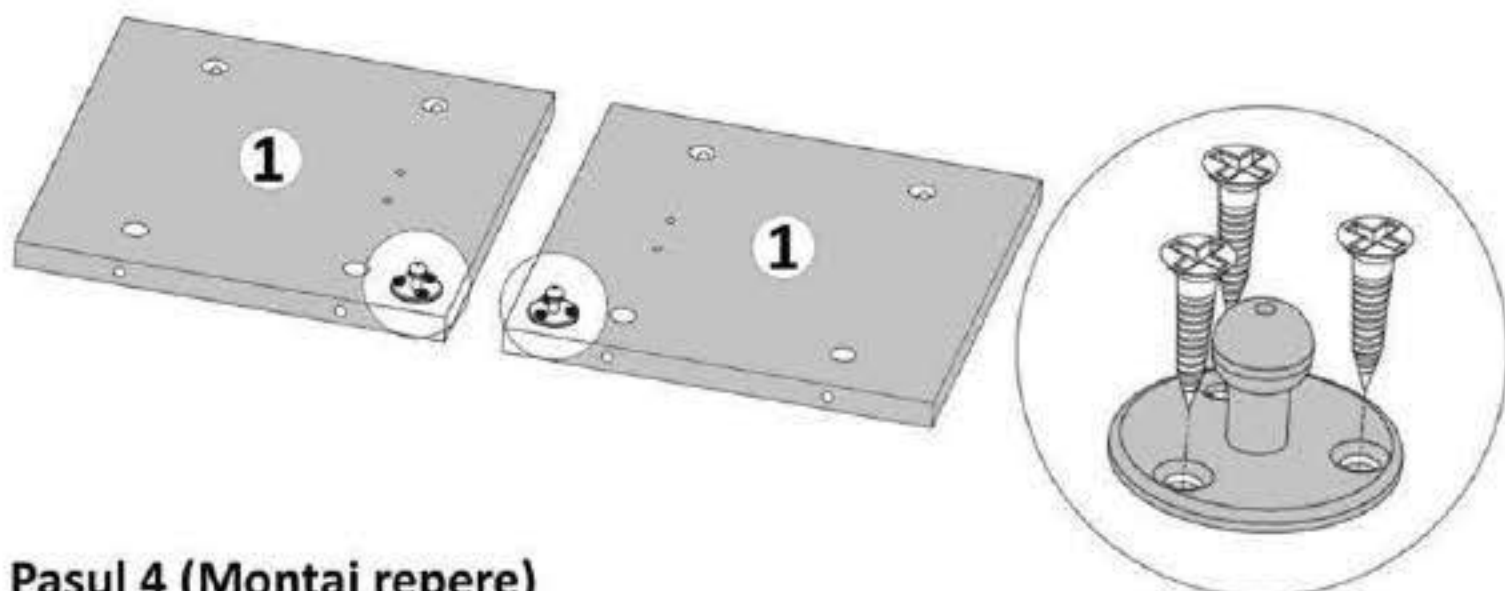

Pasul 4 (Montaj repere)

Se prind de placa laterala (3) placile (1) si (4) cu demontabili (De) x 8 buc - cate 2buc / placa in gaurile prestabilite, urmand ca apoi sa se infiletzeze (Ca)x 8 buc pana raman stranse.

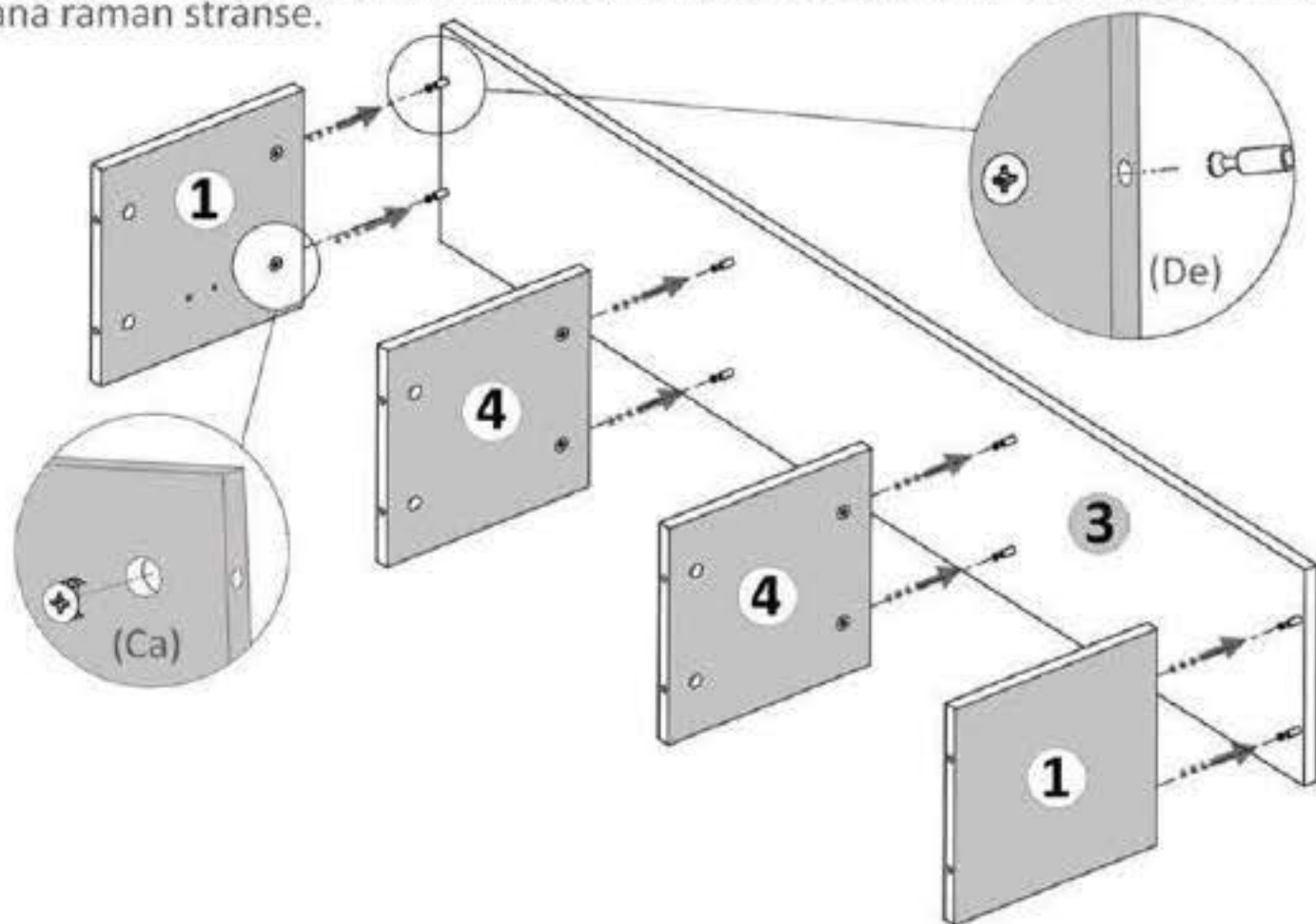

Pasul 12 (Montaj coltare)

Se monteaza pe placile (1) Coltare (Cp) x 2 buc cu suruburi (S3) 3.5x16 - 4 buc cate 2 suruburi / coltar. Aceste coltare o sa va ajute sa prindeti corpurile de perete.

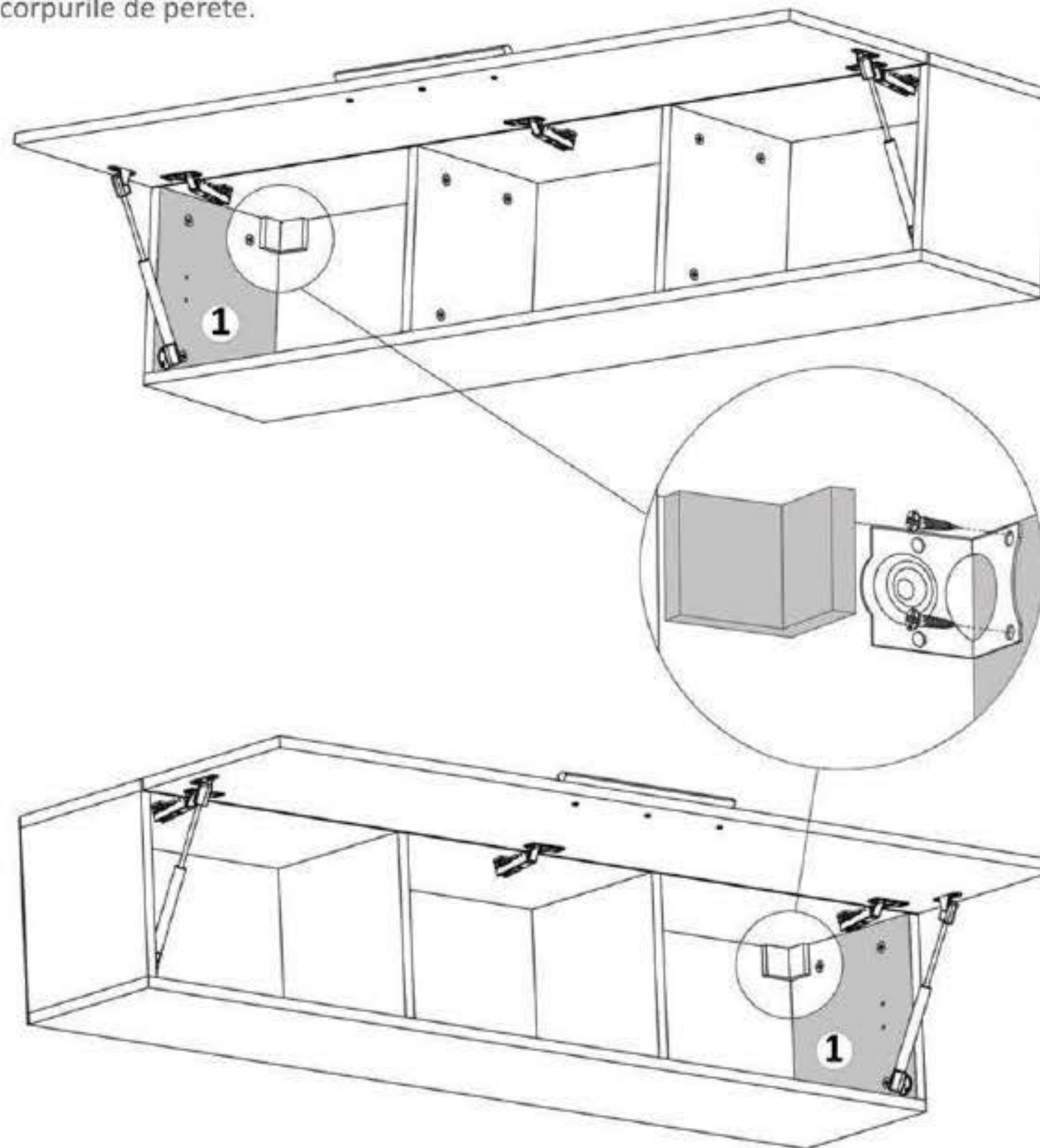

Pasul 10 (Montaj Talpa Usa Piston)

Se pozitioneaza (TU) x 2 buc pe placa (5) in locurile pe care le-ati insemnat inainte cu creionul si se prinde cu suruburi (S3) 3.5x16 -4buc cate 2 suruburi / piesa.

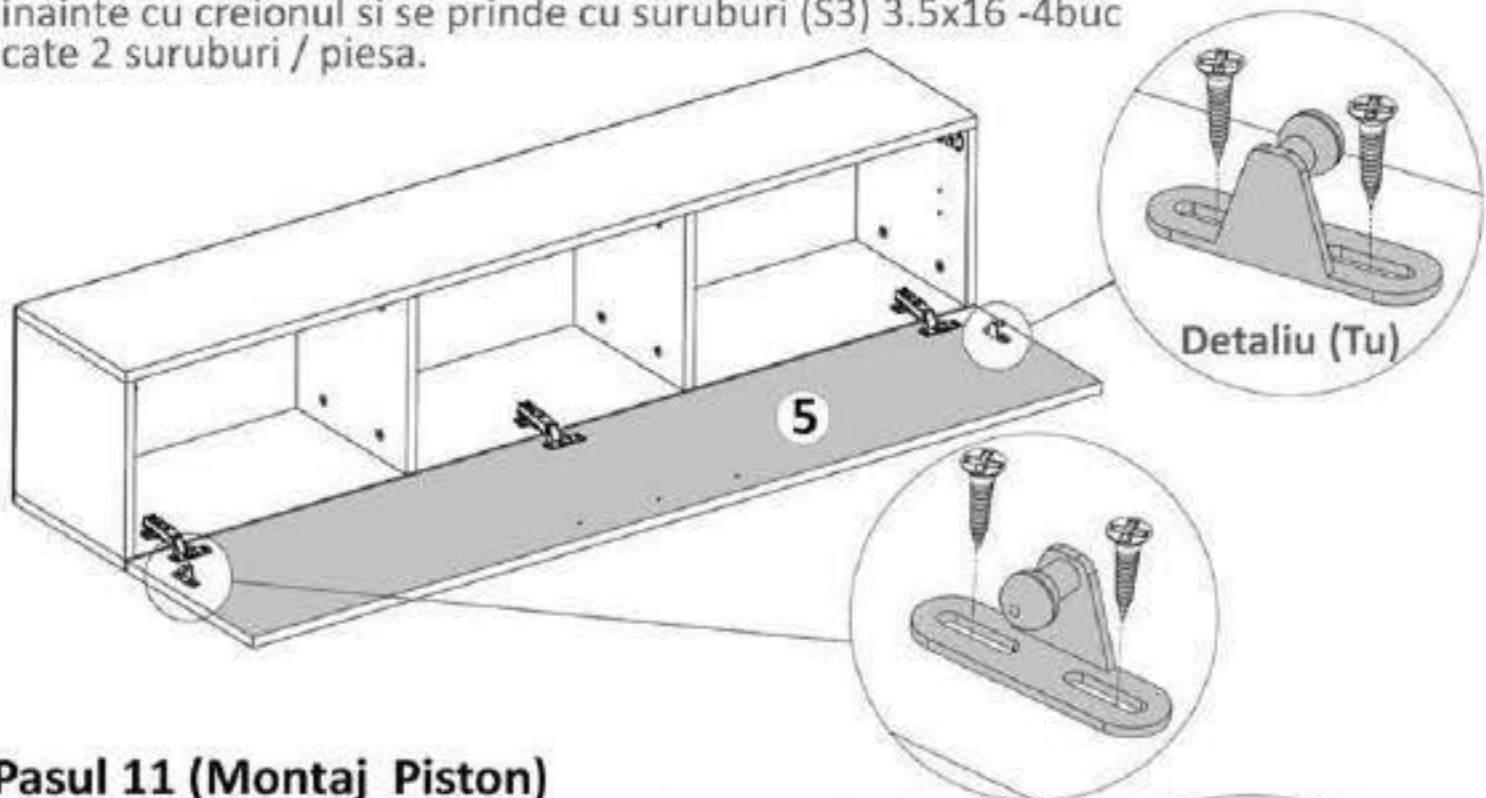

Detaliu (Tu)

Pasul 11 (Montaj Piston)

Se monteaza (Ps) x 2 buc introducand pistonul in (TU) si (TL) atat in partea dreapta cat si in partea stanga.

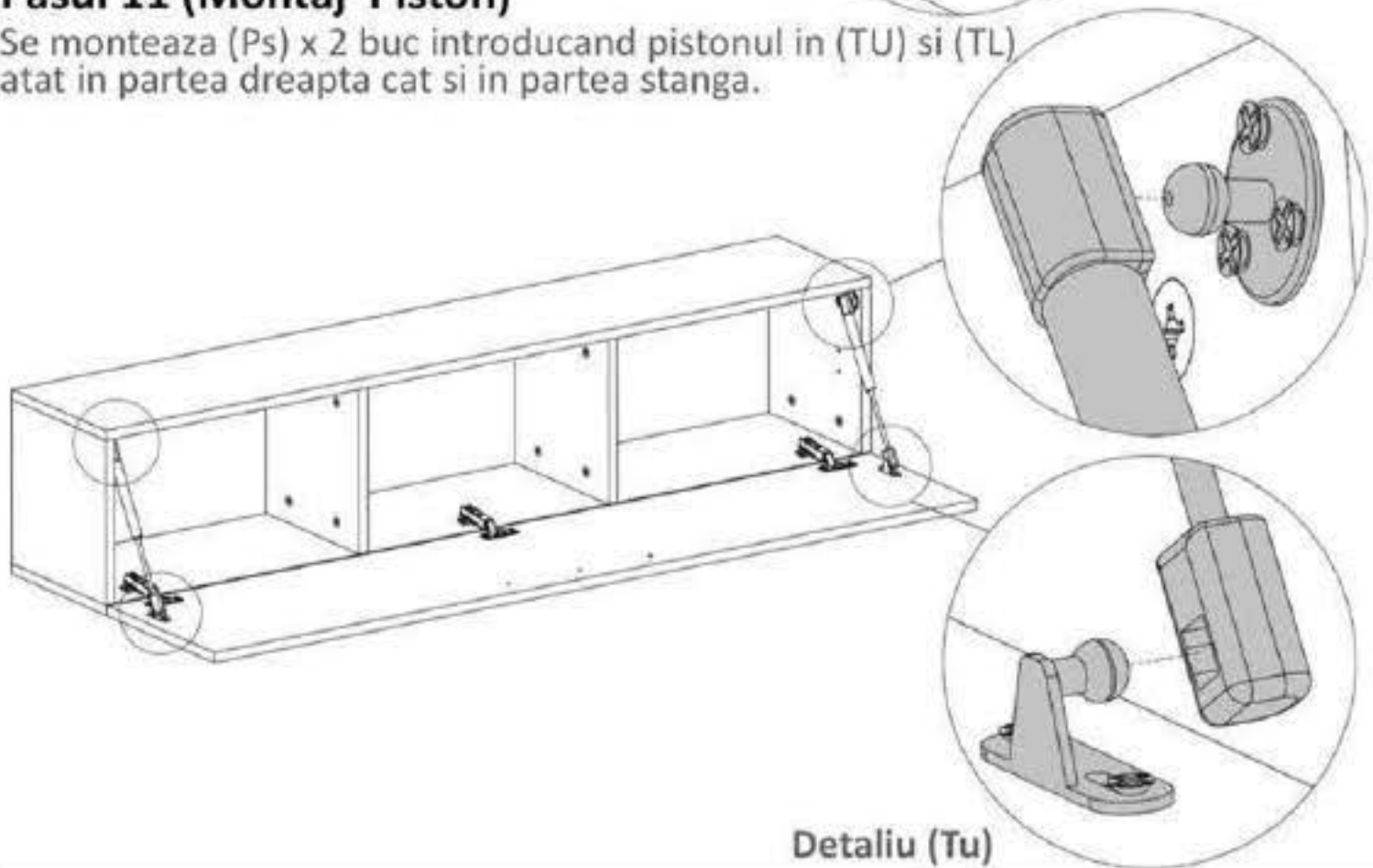

Detaliu (Tu)

Pasul 5 (Montaj repere)

Se prinde placa laterala (2) de placile (1) si (4) cu demontabili (De) x 8 buc in gaurile prestabilite, urmand ca apoi sa se infiletzeze (Ca) x 8 buc pana raman stranse.

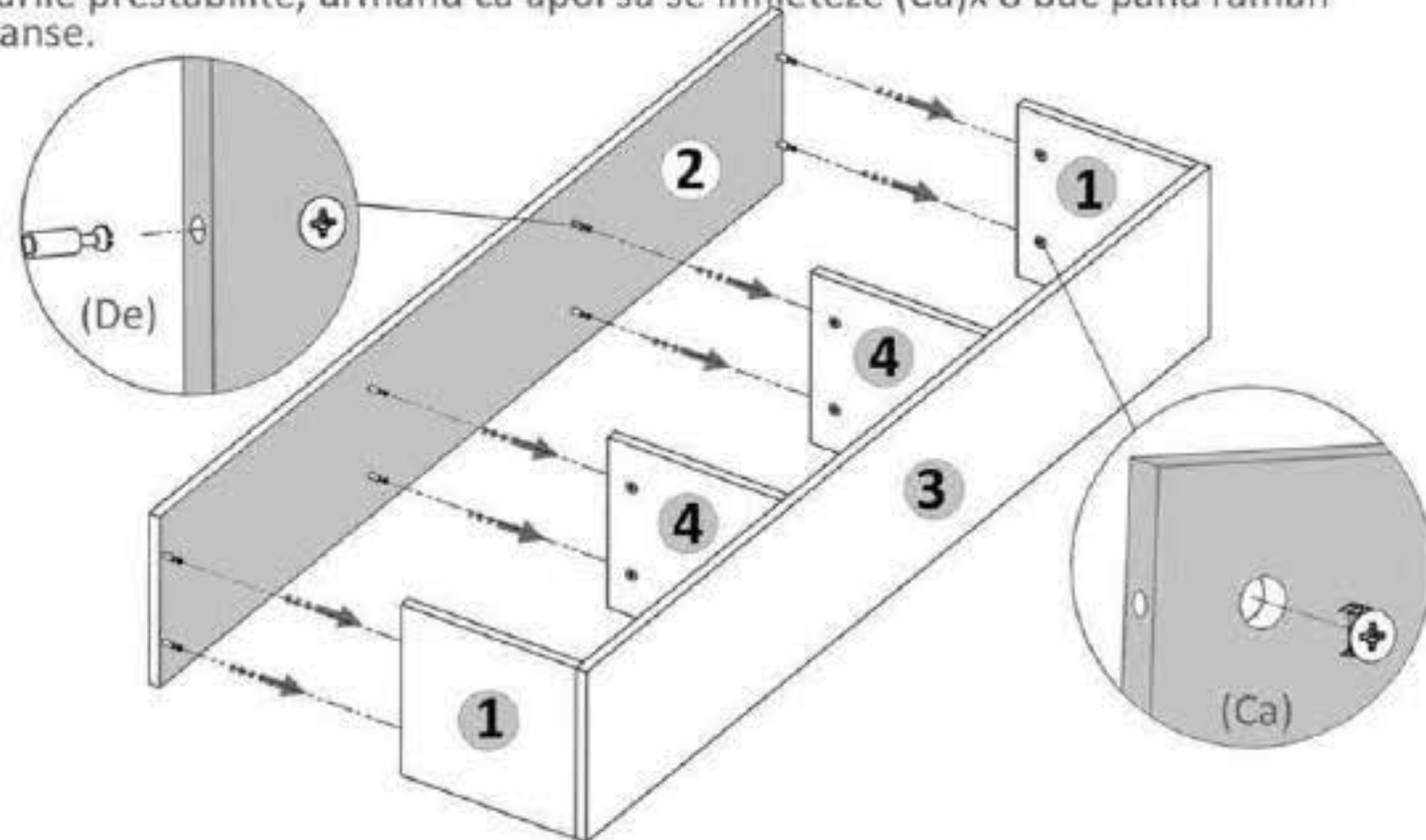

Pasul 6 (Montaj HDF)

Se masoara diagonalele sa fie in vinclu, dupa care se prinde HDF-ul (6) folosindu-se de ciocan cu ajutorul unor cuie (Cu) x 30 buc.

! Se masoara diagonalele sa fie in vinclu inainte de a monta HDF-ul!

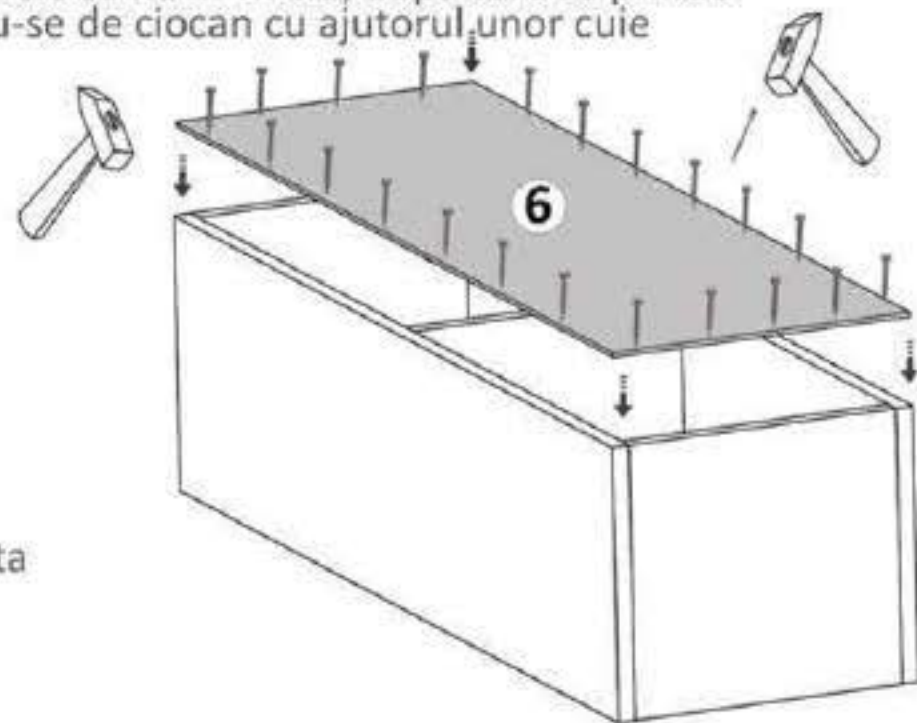

Pasul 7 (Montaj Balamale pe Usa)

Se prinde pe placa (5) balamale (Ba) x 3buc cu suruburi (S3) x 6 buc, cate 2 buc / balama.

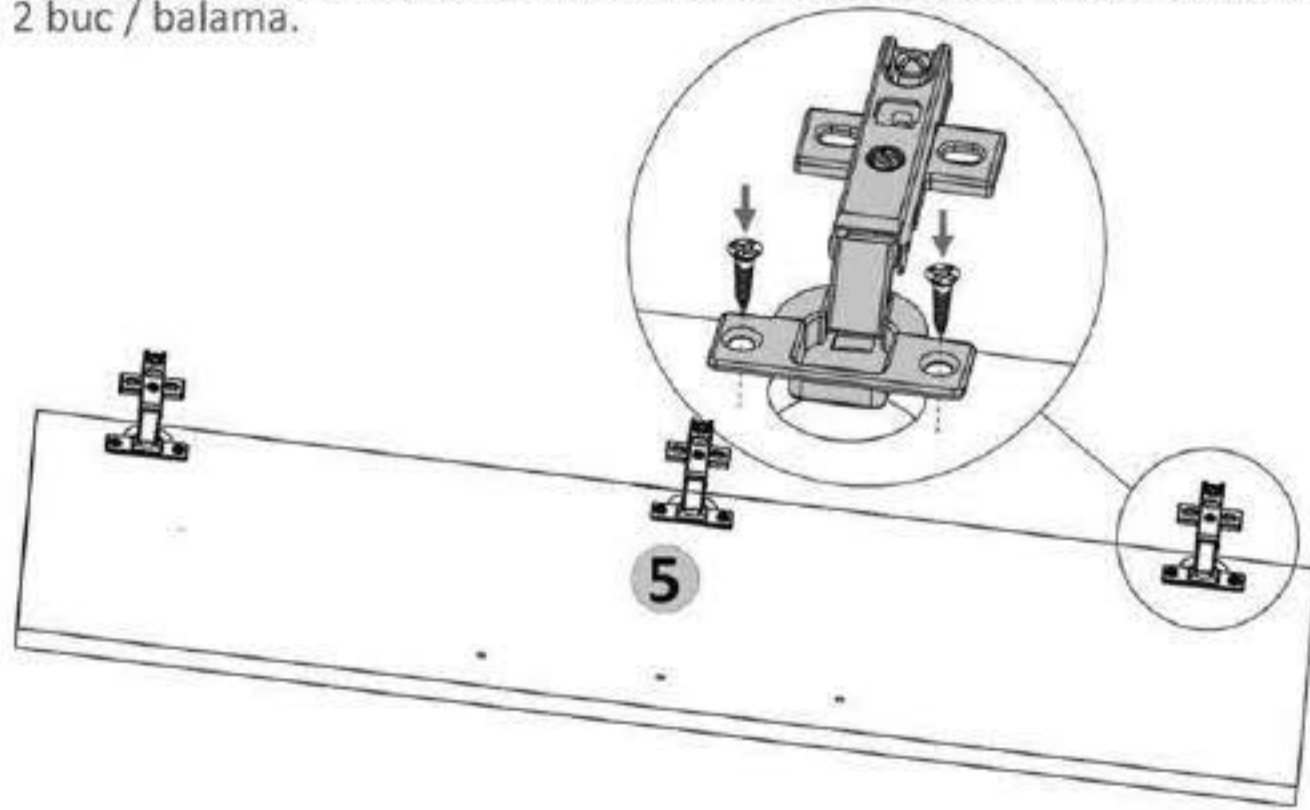

Pasul 8 (Montaj Balamale)

Se lipeste placa (5) de cantul placii (2) si se monteaza pe placa (2) balamale (Ba) x 3 buc folosindu-se suruburi 3.5x16 (S3) - cate 2 / balama.

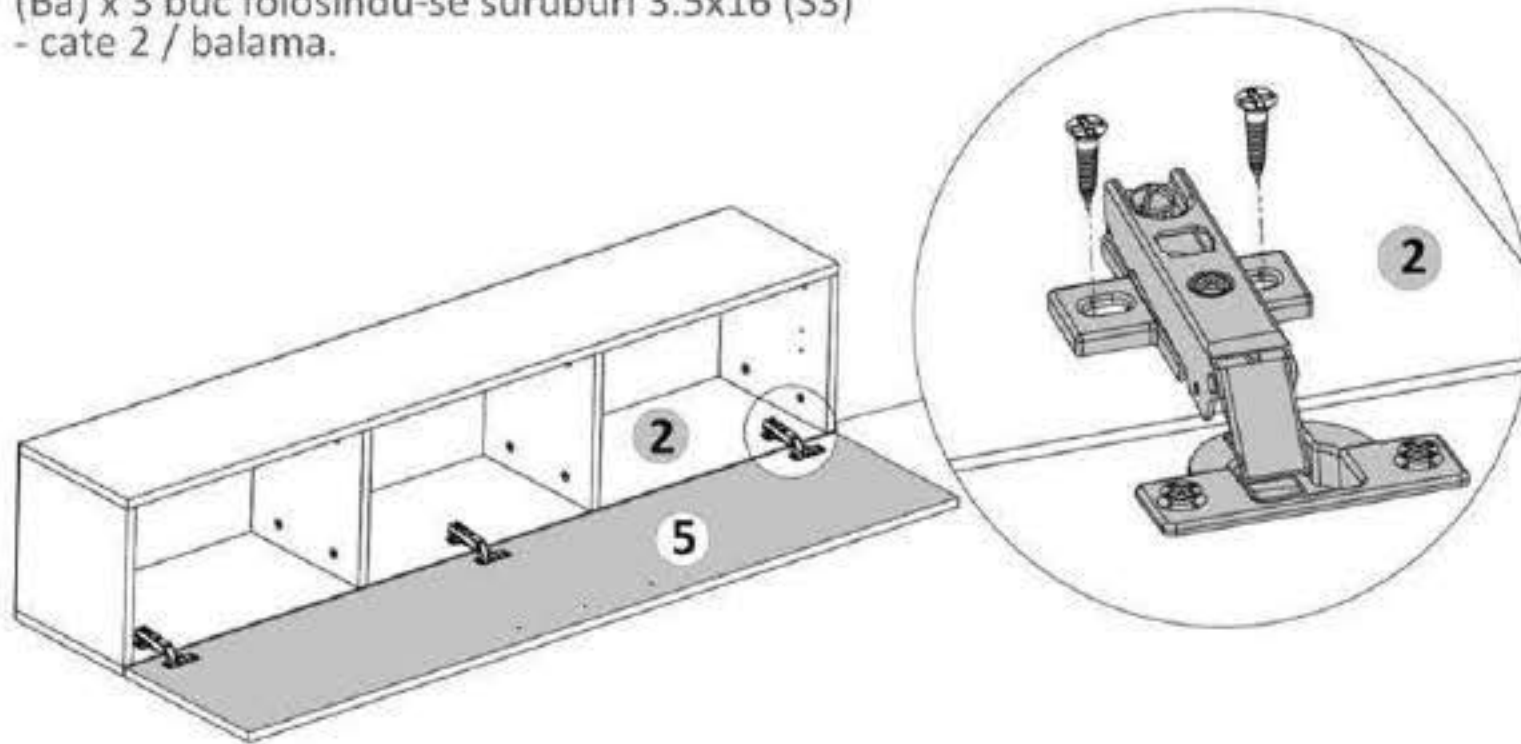

Pasul 9 (Semne pt. talpa usa piston)

Se pozitioneaza sablonul de hartie cu inscriptia (Sablon Aplicare Piston Gaz Usa - Se Foloseste la Aplicarea pe Laterală Dreapta) pe placa (5) si se perforaaza cele doua gauri cu un creion ca si in imaginea de mai jos rezultand astfel semnele necesare pentru montajul piesei (TU). (detaliu 2)

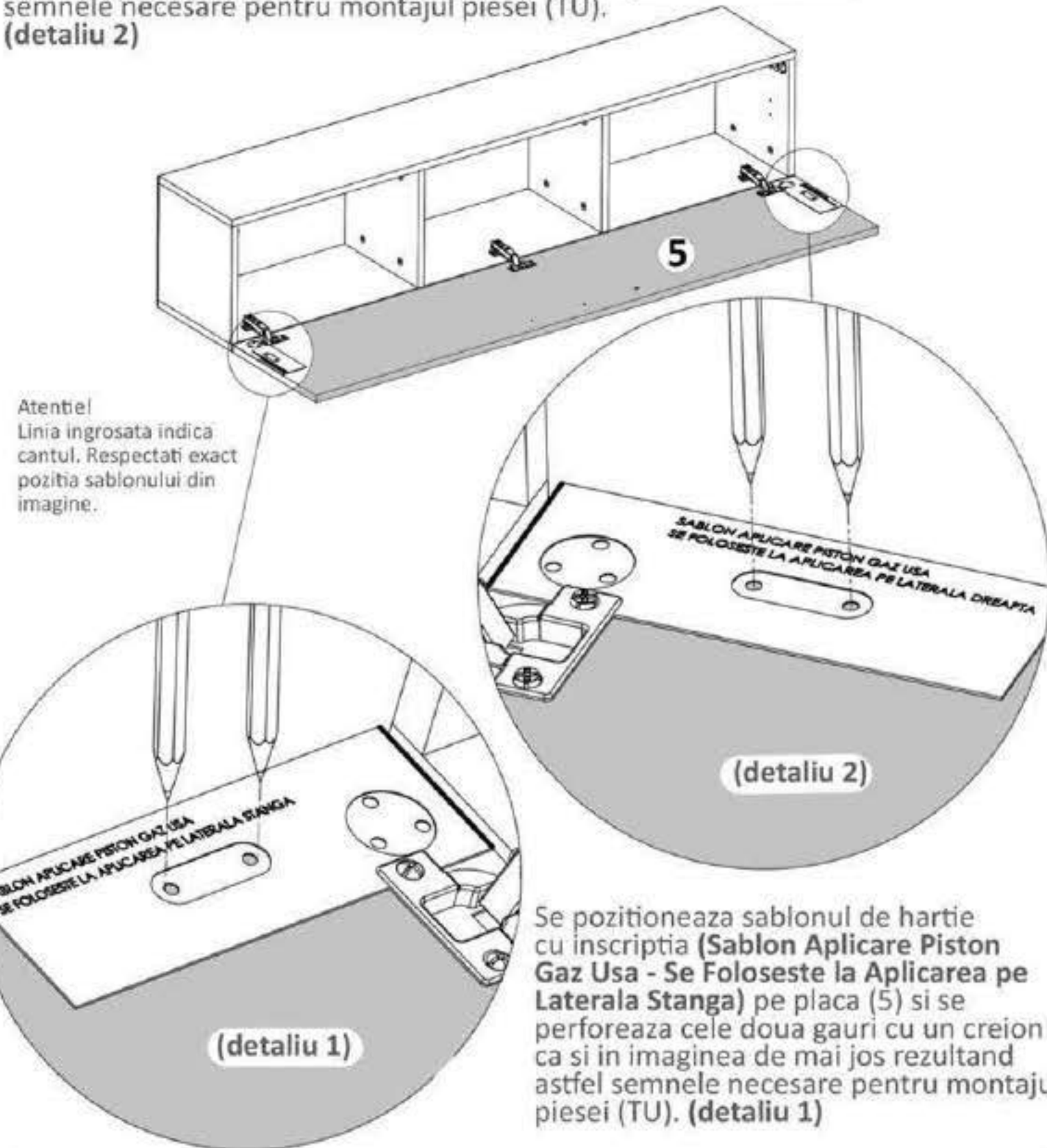

Se pozitioneaza sablonul de hartie cu inscriptia (Sablon Aplicare Piston Gaz Usa - Se Foloseste la Aplicarea pe Laterală Stanga) pe placa (5) si se perforaaza cele doua gauri cu un creion ca si in imaginea de mai jos rezultand astfel semnele necesare pentru montajul piesei (TU). (detaliu 1)