

Pasul 4 (Montaj Repere)

Se prinde placa (5) cu demontabili (De) x 4 buc in gaurile prestabilite, urmand ca apoi sa se infleteze (Ca) care trebuie puse pe placa (1) x 2 buc si pe placa (2) x 2 buc pana acestea raman stranse.

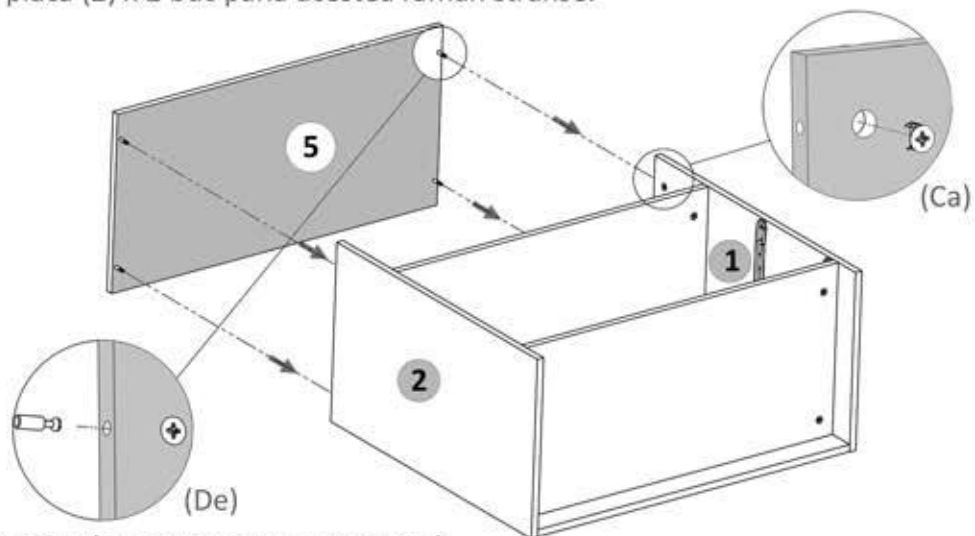

Pasul 5 (Montaj HDF + Picioare)

Se masoara diagonalele sa fie in vinclu, dupa care se prind HDF-urile (7 si 8) folosindu-se de ciocan cu ajutorul unor cuie (Cu) x 32 buc, iar la imbinari se folosesc Profile H acolo unde este spatiu gol si saibe tip cupa (Sc) unde este polita.

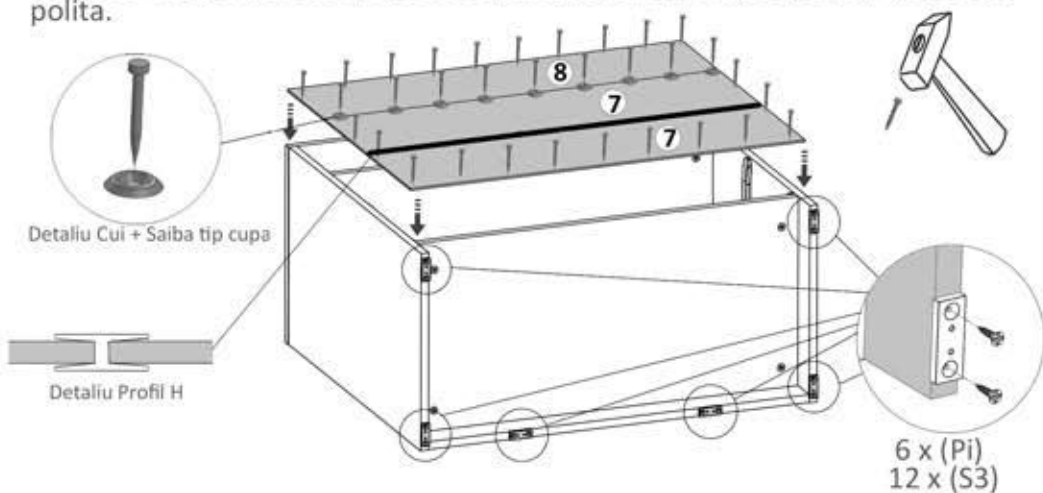

Instructiuni montaj: Carcasa Comoda

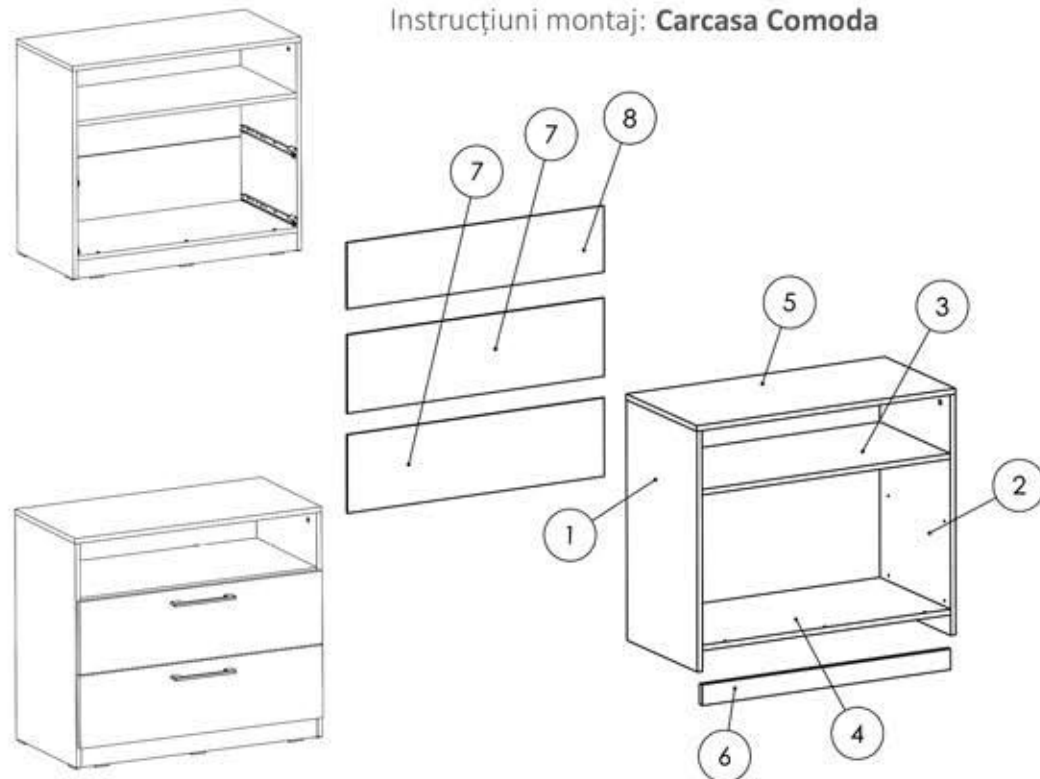

NR. REPER	COD REPER	DETALII	CANTITATE
1	LATERALA ST.	PAL 696 X 404 X 16	1
2	LATERALA DR.	PAL 696 X 404 X 16	1
3	POLITA FIXA	PAL 796 X 404 X 16	1
4	CAPAC INFERIOR	PAL 796 X 404 X 16	1
5	CAPAC SUPERIOR	PAL 830 X 404 X 16	1
6	SOCLU	PAL 796 X 60 X 16	1
7	HDF COMODA INFERIOR	HDF 824 X 227 X 4	2
8	HDF COMODA SUPERIOR	HDF 824 X 192 X 4	1

ATENȚIE: MONTAJUL NECORESPUNZĂTOR ATRAGE DUPĂ SINE PIERDEREA GARANȚIEI PRODUSULUI



Șurubelniță în cruce
sau autofiletantă











Este recomandat ca
montajul să fie făcut de
minim două persoane

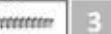

Un ciocan de dimensiune
medie

Elemente feronerie pentru 1 x Carcasa Comoda:

DEMONTABIL CU EXCENTRIC De  12	SURUB 3.5X16 S3  12	CAMA Ca  12	CONFIRMATOR 7X50 Co  3
CUIE Cu  50	GLISIERA PENTRU LATERALA ST. Gs  2	GLISIERA PENTRU LATERALA DR. Gd  2	PICIOR PLASTIC 5 mm Pi  6
		SAIBA TIP CUPA Sc  8	

Pasul 1

Se prinde cu infiletanta (Gs) x 1 buc pe placa (1) si (Gd) x 1 buc pe placa (2), fiecare cu cate 2 suruburi (S3) in gaurile punctate din placa. (Detaliu 1)

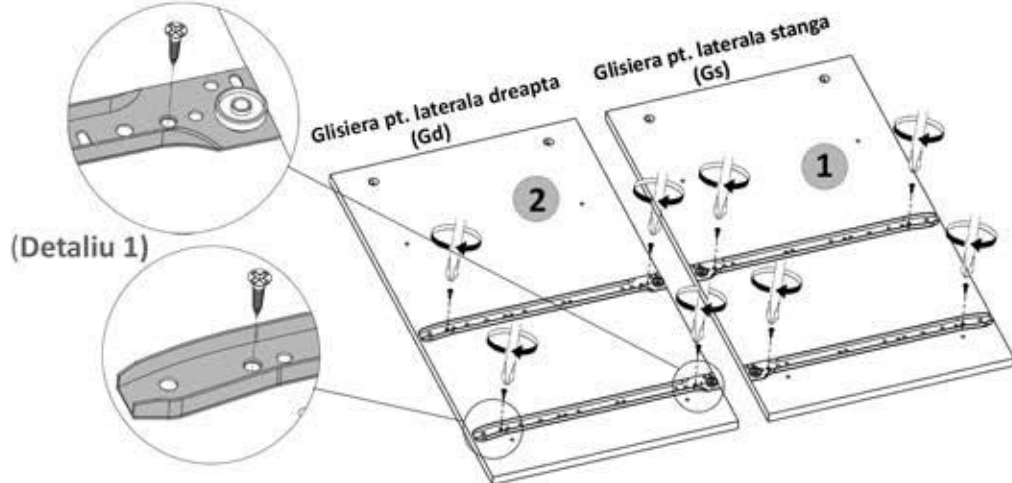

Se infileteaza cu surubelnita sau infiletanta electrica 4 x (De) pe placile (1) si (2) cate 2 / placa. (Detaliu 2)

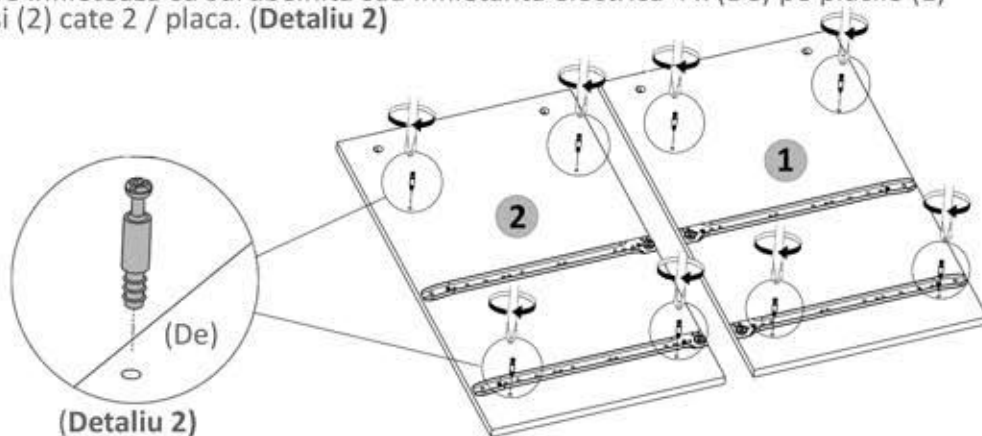

Pasul 2 (Montaj Repere)

Se prinde placa (6) de placa (4) cu ajutorul celor 3 Confirmatoare (Co) in gaurile existente pe placa (4).

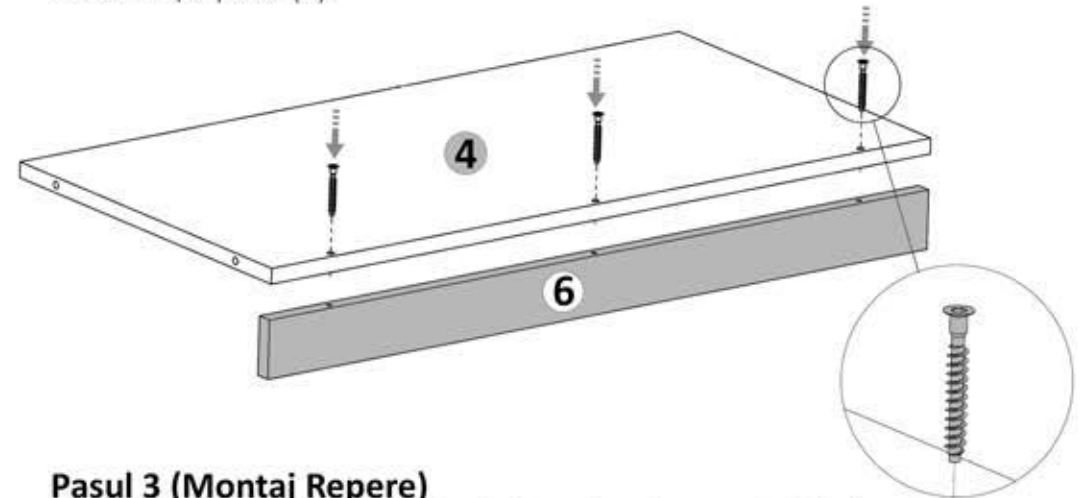

Pasul 3 (Montaj Repere)

Se prind placile (1) si (2) de placile (3,4,6) cu demontabili (De) x 8 buc in gaurile prestabilite, urmand ca apoi sa se infileteze (Ca) x 8 buc pana acestea raman stranse.

